

# Scotchman<sup>®</sup>

## Metal Fabricating Solutions



He's the best  
Fabricator  
You'll ever have.

Give him the best  
Fabricating equipment  
He'll ever use.



**American Manufacturer of Hydraulic Ironworkers,  
Pivot Circular Cold Saws and Measuring Systems.  
Importer of Excellent Quality Tube and Pipe Notchers, Upcut Saws  
and Utility Band Saw manufactured in Western Europe.**

**The Solution *PREFERRED* by Metal Fabricators**

2018

# Porta Fab 45

## STANDARD FEATURES

- 45-ton punch station (1-1/8" in 1/2")
- Keyed punch ram for safety
- 4-1/4" throat depth
- 2" die holder
- Punch nut with wrench and stripper
- One round punch & die: max. diameter 1"
- Electric remote foot pedal
- Adjustable electric stroke control with scale
- Three-in-one combination tool
  - Angle shear capacity: 3" x 3" x 5/16" at 90° and 2" x 2" x 1/4" at 45°
  - Bar shear capacity: 3/8" x 6"
  - Rod shear capacity: 3/4" round
- Tool table work area
- Slug receptacle
- Machine stand with punch & die & tooling storage rack
- 110 volt / 1-ph electric
- All guards necessary to comply with ANSI B 11-5 standards
- Three-year warranty on parts
- Made in the USA

**SINGLE OPERATOR**  
**4 STATIONS**



## CAPACITIES AND SPECIFICATIONS

RATED ON: A36 MILD STEEL / 65,000 PSI TENSILE

<b>Punching Capacity</b>	45 ton (41 mt) 1-1/8" in 1/2" (28 mm in 12 mm)	<b>Strut Shear</b>	Samples Required
<b>Special Tooling</b>	2-1/4" Max. Dia. (57 mm Max. Dia.)	<b>Square Tube Shear</b>	1/2" to 1", 12 gauge (12 to 25 mm, 2.75 mm)
<b>Throat Depth</b>	4-1/4" (108 mm)	<b>Picket Tool</b>	1/2", 3/4" & 1" (12 mm, 19 mm, 25 mm) 16 gauge (1.6 mm)
<b>Flat Bar Shear</b>	6" Length (150 mm) 1/2" x 4" (12 x 100 mm) 3/8" x 6" (10 x 150 mm)	<b>Weld Coupon Bender</b>	Max. Capacity 2" wide x 0.375" (50.8mm x 9.52mm)
<b>Angle Shear 90°</b>	3" x 3" x 5/16" (75 x 75 x 8 mm)	<b>Strokes per minute in light material</b>	20 spm (1/4" stroke) [Punch Station]
<b>Angle Shear 45°</b>	2" x 2" x 1/4" (50 x 50 x 6 mm)	<b>Strokes per minute in heavy material</b>	6 spm (3/4" stroke) [Punch Station]
<b>Round Rod Shear</b>	3/4" (20 mm)	<b>Hydraulics</b>	2,500 psi (172 bar)
<b>Brake 8"</b>	25 ton (23 mt)	<b>Motor Standard</b>	2 hp 1 ph (1.49 kW) 110 v
<b>Brake 12"</b>	20 ton (18 mt)	<b>Motor Optional</b>	2 hp 1 ph (1.49 kW) 220 v
<b>Open End Brake</b>	Max. 1/4" x 3" (6 x 76 mm) Flat or Angle Iron	<b>Dimensions</b>	W-17.63" (45 cm) L-35.75" (91 cm) H-38.75" (98 cm)
<b>Pipe Notcher Schedule 40</b>	3/4", 1", (20 mm, 25 mm) 1-1/4" (32 mm) 1-1/2", 2" (38 mm, 50 mm)	<b>Shipping Weight</b>	710 lbs. (322 kg)
<b>Rectangle Notcher</b>	2" x 1-3/4" x 1/4" (50 x 45 x 6 mm)		
<b>90° V-Notcher</b>	6" x 6" x 1/8" (150 x 150 x 3 mm)		
<b>Rod Shear Round Rod (Max.)</b>	1/4" to 1" (6 mm to 25 mm) 5 Cavity: 7/16" (11 mm), 9/16" (14 mm), 5/8" (16 mm), 3/4" (19 mm), 1" (25 mm)		
<b>Square Rod (Max.)</b>	1/4" to 3/4" (6 mm to 18 mm) 1 Cavity: 3/4" (18 mm)		

# Optional Standard Tooling

## Porta Fab 45



6" Brake



8" Brake

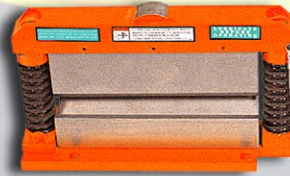

12" Brake



Open End Brake



Pipe Notcher



Rectangle Notcher



90° V-Notcher



Tube Shear



Rod Shear



Strut Shear



Weld Coupon Bender



Picket Tool

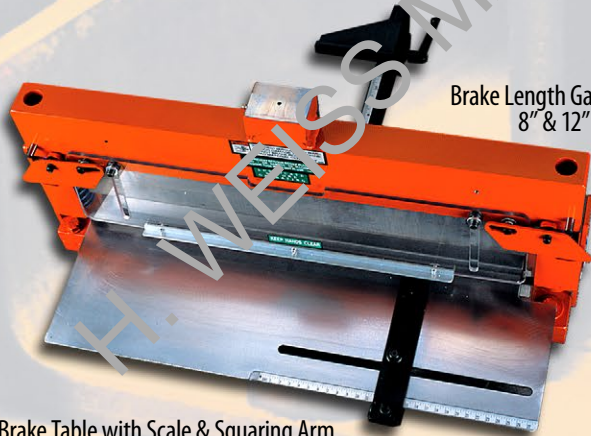

Brake Table with Scale & Squaring Arm  
12" Brake Only

Brake Length Gauge with Scale  
8" & 12" Brakes



30" Material Stop

# 50514-EC

## STANDARD FEATURES

- 50-ton punch station (1-1/4" in 1/2")
- Keyed punch ram for safety
- 6" throat depth
- 2" die holder
- Punch nut with wrench & stripper
- One round punch & die: max. diameter 1"
- Adjustable electric stroke control with scale
- Electric remote foot pedal
- Angle shear capacity: 4" x 4" x 3/8" at 90° and 2" x 2" x 3/8" at 45°
- 14" flat bar shear with 4-way reversible blade
- Rectangular Notcher: 2-1/2" x 2-3/4" x 3/8"
- Tool table work area
- Slug receptacle
- Electrical box supplied with emergency palm button and lock-out tag-out accommodations
- 230/460 Volt / 3-ph electric (must specify voltage)
- All guards necessary to comply with ANSI B 11-5 standards
- Forklift accommodations
- Three-year warranty on parts
- Made in the USA

**SINGLE OPERATOR**  
**5 STATIONS**



## CAPACITIES AND SPECIFICATIONS

RATED ON: A36 MILD STEEL / 65,000 PSI TENSILE

<b>Punching Capacity</b>	50 ton (45 mt) 1-1/4" in 1/2" (32 mm in 12 mm) 13/16" in 3/4" (21 mm in 18 mm)	<b>Strut Shear</b>	Samples Required
<b>Special Tooling</b>	2-1/4" Max. Dia. (57 mm Max. Dia.)	<b>Rod Shear</b>	
<b>Throat Depth</b>	6" (152 mm)	<b>Round Rod (Max.)</b>	1/4" to 1" (6 mm to 25 mm) 5 Cavity: 7/16" (11 mm), 9/16" (14 mm), 5/8" (16 mm), 3/4" (19 mm), 1" (25 mm)
<b>Flat Bar Shear</b>	14" Length (350 mm) 3/4" x 4" (18 x 100 mm) 1/2" x 8" (12 x 200 mm) 3/8" x 10" (10 x 250 mm) 1/4" x 14" (6 x 350 mm)	<b>Square Rod (Max.)</b>	1/4" to 3/4" (6 mm to 18 mm) 1 Cavity: 3/4" (18 mm)
<b>Opt. Sabre Blade</b>	1/2" x 10" (12 x 250 mm) 3/8" x 12" (10 x 300 mm)	<b>Square Tube Shear</b>	1/2" to 1", 12 gauge (12 x 25, 2.75 mm)
<b>Angle Shear 90°</b>	4" x 4" x 3/8" (100 x 100 x 10 mm)	<b>Picket Tool</b>	1/2", 3/4" & 1" (12 mm, 19 mm, 25 mm) 16 gauge (1.6 mm)
<b>Angle Shear 45°</b>	2" x 2" x 3/8" (50 x 50 x 10 mm)	<b>Weld Coupon Bender</b>	Max. Capacity 2" wide x 0.375" (50.8mm x 9.52mm)
<b>Brake 8"</b>	30 ton (27 mt)	<b>Strokes per minute in light material</b>	40 spm (1/4" stroke) [Punch Station]
<b>Brake 12"</b>	25 ton (23 mt)	<b>Strokes per minute in heavy material</b>	17 spm (3/4" stroke) [Punch Station]
<b>Open End Brake</b>	Max. 1/4" x 3" (6 x 76 mm) Flat or Angle Iron	<b>Hydraulics</b>	2,350 psi (163 bar)
<b>Pipe Notcher</b>	3/4", 1" (19 mm, 25 mm)	<b>Motor Standard</b>	3 hp 3 ph (2.24 kW) 230/460 208/380/575
<b>Schedule 40</b>	1-1/4" (32 mm) 1-1/2", 2" (38 mm, 50 mm)	<b>Motor Optional</b>	5 hp 1 ph (3.73 kW), 220 v
<b>Rectangle Notcher</b>	2-1/2" x 3" x 5/16" (62 x 75 x 8 mm) 2-1/2" x 2-3/4" x 3/8" (62 x 69 x 10 mm)	<b>Dimensions</b>	W-29" (74 cm) L-47" (119 cm) H-59" (150 cm)
<b>90° V-Notcher</b>	6" x 6" x 1/8" (150 x 150 x 3 mm) 3" x 3" x 1/4" (75 x 75 x 6 mm)	<b>Shipping Weight</b>	1,580 lbs. (717 kg)

# 5014-ET



**SINGLE OPERATOR**  
**7 STATIONS**



## STANDARD FEATURES

- 50-ton punch station with 3-station revolving turret (1-1/4" in 1/2")
- Keyed punch ram for safety
- 4" throat depth
- Three 2" die holders, three punch nuts with wrench and three strippers
- One round punch & die: max. diameter 1"
- Adjustable electric stroke control with scale
- Electric remote foot pedal
- Angle shear: 4" x 4" x 3/8" at 90° and 2" x 2" x 3/8" at 45°
- 14" flat bar shear with 4-way, reversible blade
- Rectangle notcher, 2-1/2" x 2-3/4" x 3/8"
- Tool table work area
- Slug receptacle
- Electrical box supplied with emergency palm button and lock-out tag-out accommodations
- 230/460 volt / 3-ph electric (must specify voltage)
- Guards necessary to comply with ANSI B 11-5 standards
- Forklift accommodations
- Three-year warranty on parts
- Made in the USA

## CAPACITIES AND SPECIFICATIONS

RATED ON: A36 MILD STEEL / 65,000 PSI TENSILE

<b>Punching Capacity</b>	50 ton (45 mt) 1-1/4" in 1/2" (32 mm in 12 mm) 13/16" in 3/4" (21 mm in 18 mm)	<b>Strut Shear</b>	Samples Required
<b>Special Tooling</b>	2-1/4" Max. Dia. (57 mm Max. Dia.)	<b>Rod Shear</b>	
<b>Throat Depth</b>	4" (100 mm)	<b>Round Rod (Max.)</b>	1/4" to 1" (6 mm to 25 mm) 5 Cavity: 7/16" (11 mm), 9/16" (14 mm), 5/8" (16 mm), 3/4" (19 mm), 1" (25 mm)
<b>Flat Bar Shear</b>	14" Length (350 mm) 3/4" x 4" (18 x 100 mm) 1/2" x 8" (12 x 200 mm) 3/8" x 10" (10 x 250 mm) 1/4" x 14" (6 x 350 mm)	<b>Square Rod (Max.)</b>	1/4" to 3/4" (6 mm to 18 mm) 1 Cavity: 3/4" (18 mm)
<b>Opt. Sabre Blade</b>	1/2" x 10" (12 x 250 mm) 3/8" x 12" (10 x 300 mm)	<b>Square Tube Shear</b>	1/2" to 1", 12 gauge (12 mm to 25 mm, 2.75 mm)
<b>Angle Shear 90°</b>	4" x 4" x 3/8" (100 x 100 x 10 mm)	<b>Picket Tool</b>	1/2", 3/4" & 1" (12 mm, 19 mm, 25 mm) 16 gauge (1.6 mm)
<b>Angle Shear 45°</b>	2" x 2" x 3/8" (50 x 50 x 10 mm)	<b>Weld Coupon Builder</b>	Max. Capacity 2" wide x 0.375" (50.8mm x 9.52mm)
<b>Brake 8"</b>	25 ton (23 mt)	<b>Strokes per minute in light material</b>	40 spm (1/4" stroke) [Punch Station]
<b>Brake 12"</b>	25 ton (23 mt)	<b>Strokes per minute in heavy material</b>	17 spm (3/4" stroke) [Punch Station]
<b>Open End Brake</b>	Max. 1/4" x 3" (6 x 76 mm) Flat or Angle Iron	<b>Hydraulics</b>	2,350 psi (163 bar)
<b>Pipe Notcher</b>	3/4", 1" (19 mm, 25 mm) 1-1/4" (32 mm) 1-1/2", 2" (38 mm, 50 mm)	<b>Motor Standard</b>	3 hp 3 ph (2.24 kW) 230/460 208/380/575
<b>Rectangle Notcher</b>	2-1/2" x 3" x 5/16" (62 x 75 x 8 mm) 2-1/2" x 2-3/4" x 3/8" (62 x 69 x 10 mm)	<b>Motor Optional</b>	5 hp 1 ph (3.73 kW) 220 v
<b>90° V-Notcher</b>	6" x 6" x 1/8" (150 x 150 x 3 mm) 3" x 3" x 1/4" (75 x 75 x 6 mm)	<b>Dimensions</b>	W-23" (59 cm) L-48" (122 cm) H-70" (178 cm)
		<b>Shipping Weight</b>	1,640 lbs. (744 kg)



# Optional Standard Tooling 50514-EC, 5014-ET

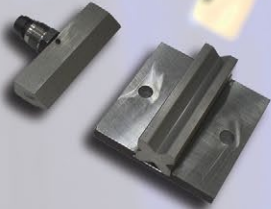

6" Brake



8" Brake



12" Brake



Open End Brake



Pipe Notcher



Strut Shear



Weld Coupon Bender



90° V-Notcher



Rod Shear



Tube Shear



Picket Tool



Punch Gauging Table with Fence & Scale 50514-EC



Shear Table with Miter Fence



Punch Gauging Table with Fence & Scale 5014-ET



Tool table extension with punch and die storage rack



48" Back Gauge

Brake Length Gauge with Scale 8" & 12" Brakes

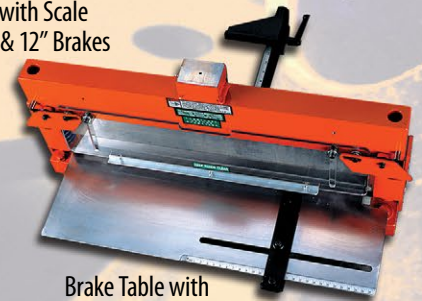

Brake Table with Scale & Squaring Arm 12" Brake Only

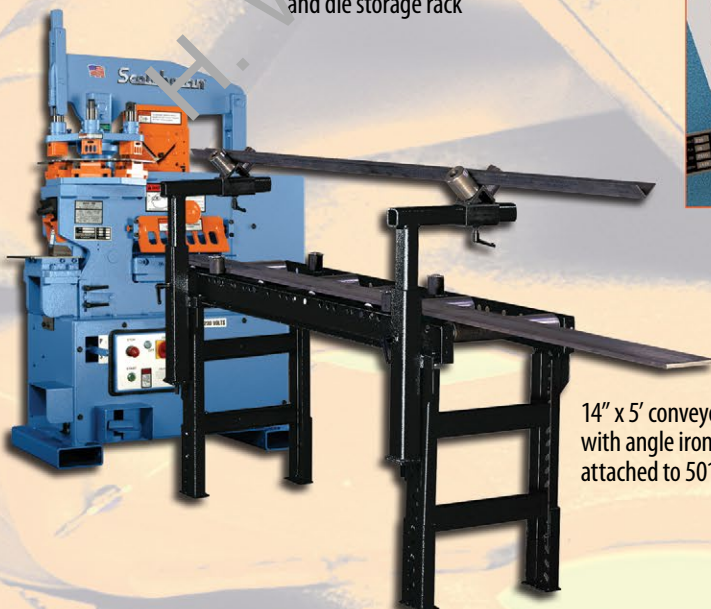

14" x 5' conveyor with angle iron support attached to 5014-ET



4" Angle Miter Guide

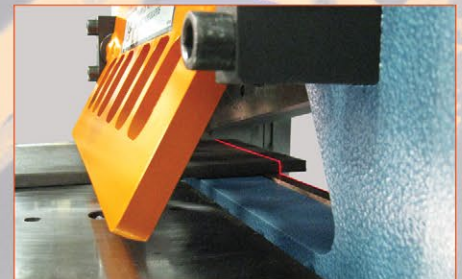

Laser Light



Multi-Loc Punch Gauging Table 40" or 90" extensions available

# 6509-24M

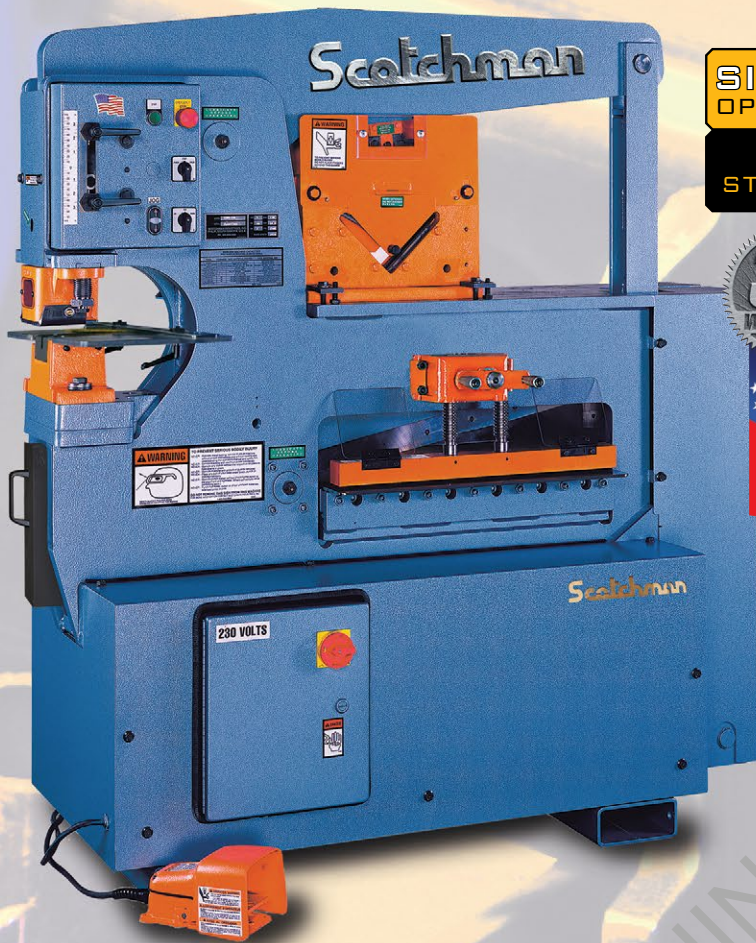

**SINGLE OPERATOR**  
**4 STATIONS**



## STANDARD FEATURES

- 65-ton punch station (1-1/16" in 3/4")
- Keyed punch ram for safety
- 9" throat depth
- Punch gauging table w/fence and scale
- Die holder complete with 2" die insert
- Punch nut with wrench and stripper
- One round punch & die: max. diameter 1-1/4"
- Punch jog control
- Adjustable electric stroke control with scale
- Electric remote foot pedal
- 24" flat bar shear with 4-way reversible blade
- Shear table with miter fence
- Angle shear capacity @ 90°:  
6" x 6" x 3/8" and 5" x 5" x 1/2"
- Tool table work area
- Slug receptacle
- Two-stage hydraulic pump
- Electrical box supplied with emergency palm button and lock-out tag-out accommodations
- 230/208 volt / 3-ph electric (must specify voltage)
- All guards necessary to comply with ANSI B 11-5 standards
- Forklift accommodations
- Three-year warranty on parts
- Made in the USA

## CAPACITIES AND SPECIFICATIONS

RATED ON: A36 MILD STEEL / 65,000 PSI TENSILE

<b>Punching Capacity</b>	65 ton (58 mt) 1-1/16" in 3/4" (27 mm in 3/4")	<b>Channel Shear</b>	2" to 5" adj. (50 mm to 125 mm adj.)
<b>Special Tooling</b>	4" Max. Dia. (101 mm Max. Dia.)	<b>Strut Shear</b>	Samples Required
<b>Throat Depth</b>	9" (225 mm)	<b>Rod Shear</b>	
<b>Flat Bar Shear</b>	24" Length (600 mm) 1" x 6" (25 x 150 mm) 3/4" x 10" (18 x 250 mm) 1/2" x 12" (12 x 300 mm) 3/8" x 16" (10 x 400 mm) 1/4" x 24" (6 x 600 mm)	Round Rod (Max.)	1/4" to 1-1/4", 9 Cavity (6 mm to 32 mm)
<b>Opt. Sabre Blade</b>	1" x 6" (25 x 150 mm) 1/2" x 16" (12 x 400 mm)	Square Rod (Max.)	1/4" to 1", 1 Cavity (6 mm to 25 mm)
<b>Angle Shear 90°</b>	6" x 6" x 3/8" (150 x 150 x 10 mm) 5" x 5" x 1/2" (125 x 125 x 12 mm)	<b>Square Tube Shear</b>	1/2" to 2", 12 gauge (12 mm to 50 mm, 2.75 mm)
<b>Angle Shear 45° (with Bar Shear)</b>	3" x 3" x 3/8" (75 x 75 x 10 mm) 4" x 4" x 1/2" (100 x 100 x 12 mm)	<b>Picket Tool</b>	1/2", 3/4" & 1" (12 mm, 19 mm, 25 mm) 16 gauge (1.6 mm)
<b>Brake 12"</b>	40 ton (36 mt)	<b>Weld Coupon Bender</b>	Max. Capacity 2" wide x 0.375" (50.8mm x 9.52mm)
<b>Brake 24"</b>	30 ton (27 mt)	<b>Offset Die Holder</b>	Max. 40 ton (36 mt)
<b>Open End Brake</b>	Max. 1/4" x 5" (6 x 125 mm) Flat or Angle Iron	<b>Strokes per minute in light material</b>	67 spm (1/4" stroke) [Punch Station]
<b>Pipe Notcher Schedule 40</b>	3/4", 1" (19 mm, 25 mm) 1-1/4" (32 mm) 1-1/2", 2" (38 mm, 50 mm)	<b>Strokes per minute in heavy material</b>	22 spm (3/4" stroke) [Punch Station]
<b>Rectangle Notcher</b>	2" x 2-1/2" x 3/8" (50 x 65 x 10 mm)	<b>Hydraulics</b>	2,600 psi (183 bar)
<b>90° V. Notcher</b>	6" x 6" x 5/16" (150 x 150 x 8 mm)	<b>Motor Standard</b>	5 hp 3 ph (3.73 kW) 230/460 208/380/575
		<b>Motor Optional</b>	5 hp 1 ph (3.73 kW) 230 v
		<b>Dimensions</b>	W-24" (57 cm) L-60" (152 cm) H-66" (168 cm)
		<b>Shipping Weight</b>	2,984 lbs. (1,353 kg)

# 9012-24M

## STANDARD FEATURES

- 90-ton punch station (1-1/8" in 1")
- Keyed punch ram for safety
- 12" throat depth
- Punch gauging table with fence and scale
- Die holder complete with 2" die insert
- Punch nut with wrench & stripper
- One round punch & die: max. diameter 1-1/4"
- Punch jog control
- Adjustable electric stroke control with scale
- Electric remote foot pedal
- Angle shear capacity: 6" x 6" x 1/2" at 90°
- 24" flat bar shear with 4-way reversible blade
- Shear table with miter fence
- Tool table work area
- Slug receptacle
- Two-stage hydraulic pump
- Electrical box supplied with emergency palm button and lock-out tag-out accommodations
- 230/460 volt / 3-ph electric (must specify voltage)
- All guards necessary to comply with ANSI B 11-5 standards
- Forklift accommodations
- Three-year warranty on parts
- Made in the USA

**SINGLE OPERATOR**

**4 STATIONS**



## CAPACITIES AND SPECIFICATIONS

RATED ON: A36 MILD STEEL / 65,000 PSI TENSILE

<b>Punching Capacity</b>	90 ton (80 mt) 1-1/8" in 1" (27 mm in 25 mm)	<b>Strut Shear</b>	Samples Required
<b>Special Tooling</b>	4" Max. Dia. (100 mm Max. Dia.)	<b>Rod Shear</b> Round Rod (Max.) Square Rod (Max.)	1/4" to 1-1/4", 9 Cavity (6 mm to 32 mm) 1/4" to 1", 1 Cavity (6 mm to 25 mm)
<b>Throat Depth</b>	12" (300 mm)	<b>Square Tube Shear</b>	1/2" to 2", 12 gauge (12 mm to 50 mm, 2.75 mm)
<b>Flat Bar Shear</b>	24" Length (600 mm) 1" x 8" (25 mm x 200 mm) 3/4" x 12" (18 x 300 mm) 1/2" x 16" (12 x 400 mm) 1/4" x 24" (6 x 600 mm)	<b>Picket Tool</b>	1/2", 3/4" & 1" (12 mm, 19 mm, 25 mm) 16 gauge (1.6 mm)
<b>Opt. Sabre Blade</b>	1/2" x 22" (12 x 550 mm) 3/8" x 24" (10 x 600 mm)	<b>Weld Coupon Bender</b>	Max. Capacity 2" wide x 0.375" (50.8mm x 9.52mm)
<b>Angle Shear 90°</b> <b>Angle Shear 45°</b> (with Bar Shear)	6" x 6" x 1/2" (150 x 150 x 12 mm) 3" x 3" x 3/8" (75 x 75 x 10 mm) 4" x 4" x 1/2" (100 x 100 x 12 mm)	<b>Offset Die Holder</b>	Max. 40 ton (36 mt)
<b>Brake 12"</b> <b>Brake 24"</b>	50 ton (45 mt) 40 ton (36 mt)	<b>Strokes per minute in light material</b>	56 spm (1/4" stroke) [Punch Station]
<b>Open End Brake</b>	Max. 1/4" x 5" (6 x 125 mm) Flat or Angle Iron	<b>Strokes per minute in heavy material</b>	19 spm (3/4" stroke) [Punch Station]
<b>Pipe Notcher</b> <b>Schedule 40</b>	3/4", 1" (20 mm, 25 mm) 1-1/4" (32 mm) 1-1/2", 2" (38 mm, 50 mm)	<b>Hydraulics</b>	2,600 psi (183 bar)
<b>Rectangle Notcher</b>	2" x 2-1/2" x 3/8" (50 x 65 x 10 mm)	<b>Motor Standard</b>	5 hp 3 ph (3.73 kW) 230/240 208/380/575
<b>90° V-Notcher</b>	6" x 6" x 5/16" (150 x 150 x 8 mm)	<b>Motor Optional</b>	5 hp 1 ph (3.73 kW) 230 v
<b>Channel Shear</b>	2" to 6" adj. (50 mm to 150 mm adj.)	<b>Dimensions</b>	W-26" (66 cm) L-76" (193 cm) H-70" (177 cm)
		<b>Shipping Weight</b>	4,204 lbs. (1,906 kg)

# 12012-24M

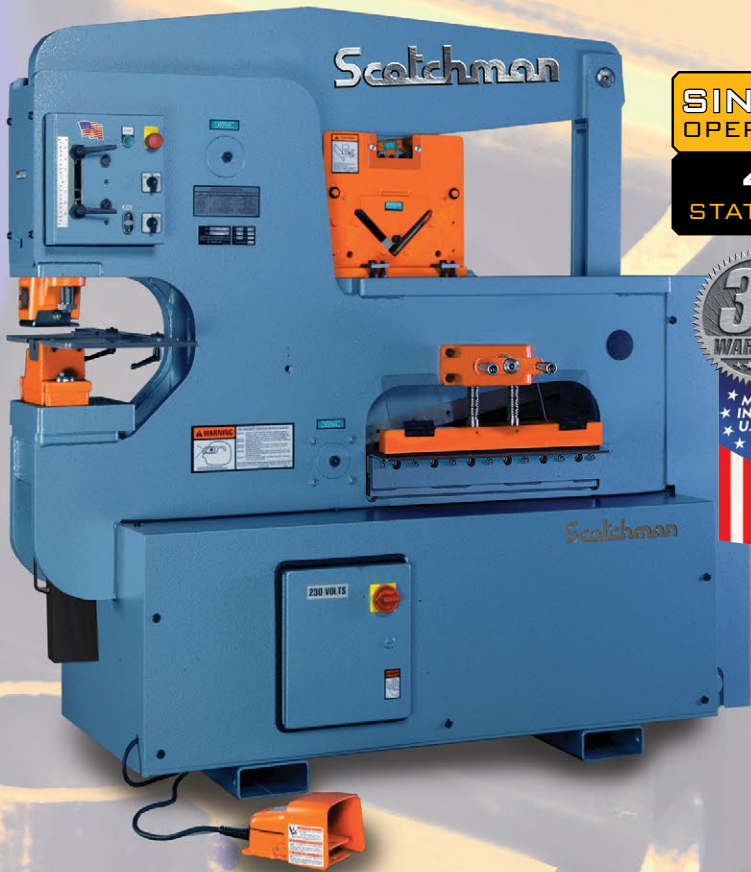

**SINGLE OPERATOR**  
**4 STATIONS**



## STANDARD FEATURES

- 120-ton punch station (1-1/2" in 1")
- Keyed punch ram for safety
- 12" throat depth
- Punch gauging table with fence and scale
- Die holder complete with 2" die insert
- Punch nut with wrench & stripper
- One round punch & die: max. diameter 1-1/4"
- Punch jog control
- Adjustable electric stroke control with scale
- Electric remote foot pedal
- Angle shear capacity 6" x 6" x 1/2" at 90°
- 24" flat bar shear with 4-way, reversible blade
- Shear table with miter feature
- Tool table work area
- Slug receptacle
- Two-stage hydraulic pump
- Electrical box supplied with emergency palm button and lock-out tag-out accommodations
- 230/460 volt /3-ph electric (must specify voltage)
- All guards necessary to comply with ANSI B-11.5 standards
- Forklift accommodations
- Three year warranty on parts
- Made in the USA

## CAPACITIES AND SPECIFICATIONS

RATED ON: A36 MILD STEEL / 65,000 PSI TENSILE

<b>Punching Capacity</b>	120 ton (108 mt) 1-1/2" in 1" (38 mm in 25 mm)	<b>Strut Shear</b>	Samples Required
<b>Special Tooling</b>	4" Max. Dia. (100 mm Max Dia.)	<b>Rod Shear</b> Round Rod (Max.) Square Rod (Max.)	1/4" to 1-1/4", 9 Cavity (6 mm to 32 mm) 1/4" to 1", 1 Cavity (6 mm to 25 mm)
<b>Throat Depth</b>	12" (300 mm)	<b>Square Tube Shear</b>	1/2" to 2", 12 gauge (12 mm to 50 mm, 2.75 mm)
<b>Flat Bar Shear</b>	24" Length (600 mm) 1" x 1" (25 x 300 mm) 3/4" x 24" (19 x 500 mm) 1/2" x 24" (12 x 600 mm)	<b>Picket Tool</b>	1/2", 3/4" & 1" (13 mm, 19 mm, 25 mm) 16 gauge (1.6 mm)
<b>Angle Shear 90°</b> <b>Angle Shear 45°</b> <b>(with Bar Shear)</b>	6" x 6" x 1/2" (150 x 150 x 12 mm) 3" x 3" x 3/8" (75 x 75 x 10 mm) 4" x 4" x 1/2" (100 x 100 x 12 mm)	<b>Weld Coupon Bender</b>	Max. Capacity 2" wide x 0.375" (50.8mm x 9.52mm)
<b>Brake 12"</b> <b>Brake 24"</b>	83 ton (75 mt) 65 ton (59 mt)	<b>Offset Die Holder</b>	Max. 40 ton (36 mt)
<b>Open End Brake</b>	Max. 1/4" x 5" (6 x 125 mm) Flat or Angle Iron	<b>Strokes per minute in light material</b>	40 spm (1/4" stroke) [Punch Station]
<b>Pipe Notcher</b> <b>Schedule 40</b>	3/4", 1" (19 mm, 25 mm) 1-1/4" (32 mm) 1-1/2", 2" (38 mm, 50 mm)	<b>Strokes per minute in heavy material</b>	13 spm (3/4" stroke) [Punch Station]
<b>Rectangle Notcher</b>	2" x 2-1/2" x 3/8" (50 x 65 x 10 mm)	<b>Hydraulics</b>	2,600 psi (183 bar)
<b>90° V-Notcher</b>	6" x 6" x 5/16" (150 x 150 x 8 mm)	<b>Motor Standard</b>	5 hp 3 ph (3.73 kW) 230/460 208/380/575
<b>Channel Shear</b>	2" to 6" adj. (50 mm to 150 mm adj.)	<b>Motor Optional</b>	5 hp 1 ph (3.73 kW) 230 v
		<b>Dimensions</b>	W-28" (71 cm) L-77" (196 cm) H-73" (185 cm)
		<b>Shipping Weight</b>	5,204 lbs. (2,360 kg)

# DO 70/110-24M

## STANDARD FEATURES

- Dual operator allows for two operators to work at the same time at full capacity
- 70-ton punch station (1-1/8" in 3/4")
- Keyed punch ram for safety
- 9" throat depth
- Punch gauging table with fence and scale
- Die holder complete with 2" die insert
- Punch nut with wrench & stripper
- Adjustable swing-away stripper
- One round punch & die: max. diameter 1-1/4"
- Punch jog control
- Two adjustable electric stroke controls with scale
- Two electric remote foot pedals
- Two 2-stage hydraulic pumps
- Two valves
- Angle shear capacity: 6" x 6" x 1/2" at 90°
- Rectangle notcher 3" x 4" x 1/2"
- Notcher table with guides
- 110-ton, 24" flat bar shear with sabre blade
- Shear table with miter fence
- Tool table work area
- Slug receptacles
- Electrical box supplied with emergency palm button and lock-out tag-out accommodations
- 230/460 volt / 3-ph electric (must specify voltage)
- All guards necessary to comply with ANSI B 11-5 standards
- Forklift accommodations
- Three-year warranty on parts
- Made in the USA

**DUAL  
OPERATOR**

**5  
STATIONS**



## CAPACITIES AND SPECIFICATIONS

RATED ON: A36 MILD STEEL / 65,000 PSI TENSILE

<b>Punching Capacity</b>	70 ton (63 mt) 1-1/8" in 3/4" (28 mm in 20 mm)	<b>Strut Shear</b>	Samples Required
<b>Special Tooling</b>	4" Max. Dia. (100 mm through 5.5 mm)	<b>Rod Shear</b> Round Rod (Max.) Square Rod (Max.)	1/4" to 1-1/4", 9 Cavity (6 mm to 32 mm) 1/4" to 1", 1 Cavity (6 mm to 25 mm)
<b>Throat Depth</b>	9" (225 mm)	<b>Square Tube Shear</b>	1/2" to 2", 12 gauge (2.75 mm)
<b>Flat Bar Shear</b> (sabre blade-std.)	110 ton, 24" Length (100 mt, 600 mm) 1" x 6", 3/4" x 12" (25 x 150 mm, 18 x 250 mm) 1/2" x 14", 3/8" x 24" (12 x 350 mm, 10 x 600 mm)	<b>Picket Tool</b>	1/2", 3/4" & 1" (12 mm, 19 mm, 25 mm) 16 gauge (1.6 mm)
<b>Angle Shear 90°</b>	6" x 6" x 1/2" (150 x 150 x 12 mm)	<b>Weld Coupon Bender</b>	Max. Capacity 2" wide x 0.375" (50.8mm x 9.52mm)
<b>Angle Shear 45°</b> (with Bar Shear)	3" x 3" x 3/8" (75 x 75 x 10 mm) 4" x 4" x 1/2" (100 x 100 x 12 mm)	<b>Offset Die Holder</b>	Max. 40 ton (36 mt)
<b>Brake 12"</b>	65 ton (59 mt)	<b>Strokes per minute</b> in light material	47 spm (1/4" stroke) [Punch Station]
<b>Brake 24"</b>	45 ton (40 mt)	<b>Strokes per minute</b> in heavy material	16 spm (3/4" stroke) [Punch Station]
<b>Open End Brake</b>	Max. 1/4" x 5" (6 x 125 mm) Flat or Angle Iron	<b>Hydraulics</b>	3,000/3,000 psi (207/207 bar)
<b>Pipe Notcher</b> Schedule 40	3/4", 1", (19 mm, 25 mm) 1-1/4", (32 mm) 1-1/2", 2" (38 mm, 50 mm)	<b>Motor Standard</b>	10 hp 3 ph (7.46 kW) 230/460 208/380/575
<b>90° V-Notcher</b>	6" x 6" x 5/16" (150 x 150 x 8 mm)	<b>Motor Optional</b>	10 hp 1 ph (7.46 kW) 230 v
<b>Rectangle Notcher</b>	3" x 5" x 3/8" (75 x 125 x 10 mm) 3" x 4" x 1/2" (75 x 100 x 12 mm)	<b>Dimensions</b>	W-30" (76 cm) L-65" (165 cm) H-72 1/8" (183 cm)
<b>V-Notch</b>	3" x 3" x 3/8" (75 x 75 x 10 mm)	<b>Shipping Weight</b>	3,800 lbs. (1,723 kg)
<b>Notching in Leg of Channel</b>	6" to 10" (150 mm to 250 mm)		
<b>Channel Shear</b>	2" to 6" adj. (50 mm to 150 mm adj.)		

# DO 95/140-24M

## STANDARD FEATURES

- Dual operator allows for two operators to work at the same time at full capacity
- 95-ton punch station (1-3/16" in 1")
- Keyed punch ram for safety
- 9" throat depth
- Punch gauging table with fence and scale
- Die holder complete with 2" die insert
- Punch nut with wrench & stripper
- Adjustable swing-away stripper
- One round punch & die: max. diameter 1-1/4"
- Punch jog control
- Two adjustable electric stroke controls with scale
- Two electric remote foot pedals
- Two 2-stage hydraulic pumps
- Two valves
- Angle shear capacity: 6" x 6" x 1/2" at 90°
- Rectangle notcher 3" x 4" x 1/2"
- Notcher table with guide
- 140-ton, 24" flat bar shear with sabre blade
- Shear table with mixer fence
- Tool table work area
- Slug receptacles
- Electrical box supplied with emergency palm button and lock-out tag-out accommodations
- 230/460 volt / 3-ph electric (must specify voltage)
- All guards necessary to comply with ANSI B 11-5 standards
- Forklift accommodations
- Three-year warranty on parts
- Made in the USA



**DUAL OPERATOR**  
**5 STATIONS**



## CAPACITIES AND SPECIFICATIONS

RATED ON: A36 MILD STEEL / 65,000 PSI TENSILE

<b>Punching Capacity</b>	95 ton (86 mt) 1-3/16" in 1" (27 mm in 25 mm)	<b>Strut Shear</b>	Samples Required
<b>Special Tooling</b>	4" Max. Dia. (100 mm through 3.5 mm)	<b>Rod Shear</b>	
<b>Throat Depth</b>	9" (225 mm)	<b>Round Rod (Max.)</b>	1/4" to 1-1/4", 9 Cavity (6 mm to 32 mm)
<b>Flat Bar Shear (sabre blade-std.)</b>	140 ton, 24" Length, (127 mt, 609 mm) 1" x 8", 3/4" x 12" (25 x 203 mm, 18 x 304 mm) 1/2" x 16", 3/8" x 24" (12 x 406 mm, 10 x 609 mm)	<b>Square Rod (Max.)</b>	1/4" to 1", 1 Cavity (6 mm to 25 mm)
<b>Angle Shear 90°</b>	6" x 6" x 1/2" (150 x 150 x 12 mm)	<b>Square Tube Shear</b>	1/2" to 2", 12 gauge (2.75 mm)
<b>Angle Shear 45° (with Bar Shear)</b>	3" x 3" x 3/8" (75 x 75 x 10 mm) 1" x 4" x 1/2" (100 x 100 x 12 mm)	<b>Picket Tool</b>	1/2", 3/4" & 1" (12 mm, 19 mm, 25 mm) 16 gauge (1.6 mm)
<b>Brake 12"</b>	80 ton (72.5 mt)	<b>Weld Coupon Bender</b>	Max. Capacity 2" wide x 0.375" (50.8mm x 9.52mm)
<b>Brake 24"</b>	55 ton (50 mt)	<b>Offset Die Holder</b>	Max. 40 ton (36 mt)
<b>Open End Brake</b>	Max. 1/4" x 5" (6 x 125 mm) Flat or Angle Iron	<b>Strokes per minute in light material</b>	47 spm (1/4" stroke) [Punch Station]
<b>Pipe Notcher Schedule 40</b>	3/4", 1", (19 mm, 25 mm) 1-1/4", (32 mm) 1-1/2", 2" (38 mm, 50 mm)	<b>Strokes per minute in heavy material</b>	16 spm (3/4" stroke) [Punch Station]
<b>90° V-Notcher</b>	6" x 6" x 5/16" (150 x 150 x 8 mm)	<b>Hydraulics</b>	3,500/3,500 psi (241/241 bar)
<b>Rectangle Notcher</b>	3" x 5" x 3/8" (75 x 125 x 10 mm) 3" x 4" x 1/2" (75 x 100 x 12 mm)	<b>Motor Standard</b>	10 hp 3 ph (7.46 kW) 230/460 208/380/575
<b>V-Notch</b>	3" x 3" x 3/8" (75 x 75 x 10 mm)	<b>Motor Optional</b>	10 hp 1 ph (7.46 kW) 230 v
<b>Notching in Leg of Channel</b>	6" to 10" (150 mm to 250 mm)	<b>Dimensions</b>	W-30" (76 cm) L-65" (165 cm) H-72 1/8" (183 cm)
<b>Channel Shear</b>	2" to 6" adj. (50 mm to 150 mm adj.)	<b>Shipping Weight</b>	3,800 lbs. (1,723 kg)

# DO 120/200-24M

## STANDARD FEATURES

- Dual operator allows for two operators to work at the same time at full capacity
- 120-ton punch station (1-1/2" in 1")
- Keyed punch ram for safety
- 12" throat depth
- Punch gauging table with fence and scale
- Die holder complete with 2" die insert
- Punch nut with wrench & stripper
- Adjustable swing-away stripper
- One round punch & die: max. diameter 1-1/4"
- Punch jog control
- Two electric remote foot pedals
- Two adjustable electric stroke controls with scale
- Two 2-stage hydraulic pumps
- Two valves
- Angle shear capacity: 6" x 6" x 1/2" at 90°
- Rectangle notcher 3" x 5-3/4" x 1/2"
- Notcher table with guides
- 200-ton, 24" flat bar shear with sabre blade
- Shear table with miter fence
- Tool table work area
- Slug receptacles
- Electrical box supplied with emergency palm button and lock-out tag-out accommodations
- 230/460 volt / 3-ph electric (must specify voltage)
- All guards necessary to comply with ANSI B 11-5 standards
- Forklift accommodations
- Three-year warranty on parts
- Made in the USA

**DUAL  
OPERATOR**

**5  
STATIONS**



## CAPACITIES AND SPECIFICATIONS

RATED ON: A36 MILD STEEL / 65,000 PSI TENSILE

<b>Punching Capacity</b>	120 ton (108 mt) 1-1/2" in 1" (38 mm in 25 mm)	<b>Strut Shear</b>	Samples Required
<b>Special Tooling</b>	4" Max. Dia. (100 mm Max. Dia.)	<b>Rod Shear</b> Round Rod (Max.) Square Rod (Max.)	1/4" to 1-1/4", 9 Cavity (6 mm to 32 mm) 1/4" to 1", 1 Cavity (6 mm to 25 mm)
<b>Throat Depth</b>	12" (300 mm)	<b>Square Tube Shear</b>	1/2" to 2", 12 gauge (12 mm to 50 mm, 2.75 mm)
<b>Flat Bar Shear (sabre blade-std.)</b>	200 ton, 24" Length (600 mm) 1" x 12" (25 x 500 mm) 2 1/4" x 20" (8 x 500 mm) 1 1/2" x 24" (12 x 600 mm)	<b>Picket Tool</b>	1/2", 3/4" & 1" (12 mm, 19 mm, 25 mm) 16 gauge (1.6 mm)
<b>Angle Shear 90°</b>	6" x 6" x 1/2" (150 x 150 x 12 mm)	<b>Weld Coupon Bender</b>	Max. Capacity 2" wide x 0.375" (50.8mm x 9.52mm)
<b>Angle Shear 45° (with Bar Shear)</b>	3" x 3" x 3/8" (75 x 75 x 10 mm) 4" x 4" x 1/2" (100 x 100 x 12 mm)	<b>Offset Die Holder</b>	Max. 40 ton (36 mt)
<b>Brake 12"</b>	75 ton (55 mt)	<b>Strokes per minute in light material</b>	47 spm (1/4" stroke) [Punch Station]
<b>Brake 24"</b>	55 ton (40 mt)	<b>Strokes per minute in heavy material</b>	16 spm (3/4" stroke) [Punch Station]
<b>Open End Brake</b>	Max. 1/4" x 5" (6 x 125 mm) Flat or Angle Iron	<b>Hydraulics</b>	3,500/3,500 psi (207/207 bar)
<b>Pipe Notcher Schedule 40</b>	3/4", 1" (19 mm, 25 mm) 1-1/4" (32 mm) 1-1/2", 2" (38 mm, 50 mm)	<b>Motor Standard</b>	10 hp 3 ph (7.46 kW) 230/460 208/380/575
<b>90° V-Notcher</b>	6" x 6" x 5/16" (150 x 150 x 8 mm)	<b>Motor Optional</b>	10 hp 1 ph (7.46 kW) 230 v
<b>Rectangle Notcher</b>	3" x 5-3/4" x 1/2" (75 x 145 x 12 mm)	<b>Dimensions</b>	W-34" (119 cm) L-77-1/4" (174 cm) H-74 1/4" (187 cm)
<b>V-Notch</b>	3" x 3" x 1/2" (75 x 75 x 12 mm)	<b>Shipping Weight</b>	6,204 lbs. (2,814 kg)
<b>Notching in Leg of Channel</b>	6" to 10" (150 mm to 250 mm)		
<b>Channel Shear</b>	2" to 6" adj. (50 mm to 150 mm)		

# DO 135/220-24M



**DUAL OPERATOR**  
**5 STATIONS**

**3YR WARRANTY**  
**MADE IN THE U.S.A.**

## STANDARD FEATURES

- Dual operator allows for two operators to work at the same time at full capacity
- 135-ton punch station (1-11/16" in 1")
- Keyed punch ram for safety
- 12" throat depth
- Punch gauging table with fence and scale
- Die Holder complete with a die insert
- Punch nut with wrench & stripper
- Adjustable swing-away stripper
- One round punch & die: max. diameter 1-1/4"
- Punch jog control
- Two electric remote foot pedals
- Two adjustable electric stroke controls with scale
- Two 2-stage hydraulic pumps
- Two valves
- Angle shear capacity: 6" x 6" x 1/2" at 90°
- Rectangle notcher: 3" x 5-3/4" x 1/2"
- Notcher table with guides
- 220-ton, 24" flat bar shear with sabre blade
- Shear table with miter fence
- True table work area
- Sluice receptacles
- Electrical box supplied with emergency palm button and lock-out tag-out accommodations
- 230/460 volt / 3-ph electric (must specify voltage)
- All guards necessary to comply with ANSI B 11-5 standards
- Forklift accommodations
- Three-year warranty on parts
- Made in the USA

## CAPACITIES AND SPECIFICATIONS

RATED ON: A36 MILD STEEL / 65,000 PSI TENSILE

<b>Punching Capacity</b>	135 ton (122 mt) 1-11/16" in 1" (43 mm in 25 mm)
<b>Special Tooling</b>	4" Max. Dia. (100 mm Max. Dia.)
<b>Throat Depth</b>	12" (300 mm)
<b>Flat Bar Shear (sabre blade-std.)</b>	220 ton, 24" length (600 mm) 7" x 1/2" (25 x 300 mm) 3/4" x 20" (18 x 500 mm) 1/2" x 24" (12 x 600 mm)
<b>Angle Shear 90°</b>	6" x 6" x 1/2" (150 x 150 x 12 mm)
<b>Angle Shear 45° (with Bar Shear)</b>	3" x 3" x 3/8" (75 x 75 x 10 mm) 4" x 4" x 1/2" (100 x 100 x 12 mm)
<b>Brake 12"</b>	90 ton (81.6 mt)
<b>Brake 24"</b>	70 ton (63.5 mt)
<b>Open End Brake</b>	Max. 1/4" x 5" (6 x 125 mm) Flat or Angle Iron
<b>Pipe Notcher Schedule 40</b>	3/4", 1" (19 mm, 25 mm) 1-1/4" (32 mm) 1-1/2", 2" (38 mm, 50 mm)
<b>90° V-Notcher</b>	6" x 6" x 5/16" (150 x 150 x 8 mm)
<b>Rectangle Notcher</b>	3" x 5-3/4" x 1/2" (75 x 145 x 12 mm)
<b>V-Notch</b>	3" x 3" x 1/2" (75 x 75 x 12 mm)
<b>Notching in Leg of Channel</b>	6" to 10" (150 mm to 250 mm)
<b>Channel Shear</b>	2" to 6" adj. (50 mm to 150 mm)

<b>Strut Shear</b>	Samples Required
<b>Rod Shear</b>	
Round Rod (Max.)	1/4" to 1-1/4", 9 Cavity (6 mm to 32 mm)
Square Rod (Max.)	1/4" to 1", 1 Cavity (6 mm to 25 mm)
<b>Square Tube Shear</b>	1/2" to 2", 12 gauge (12 mm to 50 mm, 2.75 mm)
<b>Picket Tool</b>	1/2", 3/4" & 1" (12 mm, 19 mm, 25 mm) 16 gauge (1.6 mm)
<b>Weld Coupon Bender</b>	Max. Capacity 2" wide x 0.375" (50.8mm x 9.52mm)
<b>Offset Die Holder</b>	Max. 40 ton (36 mt)
<b>Strokes per minute in light material</b>	47 spm (1/4" stroke) [Punch Station]
<b>Strokes per minute in heavy material</b>	16 spm (3/4" stroke) [Punch Station]
<b>Hydraulics</b>	3,500/3,500 psi (207/207 bar)
<b>Motor Standard</b>	10 hp 3 ph (7.46 kW) 230/460 208/380/575
<b>Motor Optional</b>	10 hp 1 ph (7.46 kW) 230 v
<b>Dimensions</b>	W-34" (119 cm) L-77-1/4" (174 cm) H-74 1/4" (187 cm)
<b>Shipping Weight</b>	6,204 lbs. (2,814 kg)

# DO 150/240-24M

## STANDARD FEATURES

- Dual operator allows for two operators to work at the same time at full capacity
- 150-ton punch station (1-7/8" in 1")
- Keyed punch ram for safety
- 12" throat depth
- Punch gauging table with fence and scale
- Die Holder complete with a die insert
- Punch nut with wrench & stripper
- Adjustable swing-away stripper
- One round punch & die: max. diameter 1-1/4"
- Punch jog control
- Two electric remote foot pedals
- Two adjustable electric stroke controls with scale
- Two 2-stage hydraulic pumps
- Two valves
- Angle shear capacity: 6" x 6" x 1/2" at 90°
- Rectangle notcher 3" x 5-3/4" x 1/2"
- Notcher table with guides
- 240-ton, 24" flat bar shear with sabre blade
- Shear table with miter fence
- Tool table and work area
- Slug receptacles
- Electrical box supplied with emergency palm button and lock-out tag-out accommodations
- 230/460 volt / 3-ph electric (must specify voltage)
- All guards necessary to comply with ANSI B 11-5 standards
- Forklift accommodations
- Three-year warranty on parts
- Made in the USA

**DUAL  
OPERATOR**

**5  
STATIONS**



## CAPACITIES AND SPECIFICATIONS

RATED ON: A36 MILD STEEL / 65,000 PSI TENSILE

<b>Punching Capacity</b>	150 ton (136 mt) 1-1/2" in 1-1/4" (38 mm in 32 mm) 1-7/8" in 1" (48 mm in 25 mm) 2-1/2" in 3/4" (63 mm in 19 mm)	<b>Channel Shear</b>	2" to 6" adj. (50 mm to 150 mm)
<b>Special Tooling</b>	4" Max. Dia. (100 mm Max. Dia.)	<b>Strut Shear</b>	Samples Required
<b>Throat Depth</b>	12" (300 mm)	<b>Rod Shear</b>	
<b>Flat Bar Shear (sabre blade-std.)</b>	240 ton, 24" Length (600 mm) 1" x 1-1/2" (25 x 355 mm) 3/4" x 24" (19 x 610 mm)	<b>Round Rod (Max.)</b>	1/4" to 1-1/4", 9 Cavity (6 mm to 32 mm)
<b>Angle Shear 90°</b>	6" x 6" x 1/2" (150 x 150 x 12 mm)	<b>Square Rod (Max.)</b>	1/4" to 1", 1 Cavity (6 mm to 25 mm)
<b>Angle Shear 45° (with Bar Shear)</b>	3" x 3" x 3/8" (75 x 75 x 10 mm) 4" x 4" x 1/2" (100 x 100 x 12 mm)	<b>Square Tube Shear</b>	1/2" to 2", 12 gauge (12 mm to 50 mm, 2.75 mm)
<b>Brake 12"</b>	90 ton (81.6 mt)	<b>Picket Tool</b>	1/2", 3/4" & 1" (12 mm, 19 mm, 25 mm) 16 gauge (1.6 mm)
<b>Brake 24"</b>	70 ton (63.5 mt)	<b>Weld Coupon Bender</b>	Max. Capacity 2" wide x 0.375" (50.8mm x 9.52mm)
<b>Open End Brake</b>	Max. 1/4" x 5" (6 x 125 mm) Flat or Angle Iron	<b>Offset Die Holder</b>	Max. 40 ton (36 mm)
<b>Pipe Notcher Schedule 40</b>	3/4", 1" (19 mm, 25 mm) 1-1/4" (32 mm) 1-1/2", 2" (38 mm, 50 mm)	<b>Strokes per minute in light material</b>	52 spm (1/4" stroke) [Punch Station]
<b>90° V-Notcher</b>	6" x 6" x 5/16" (150 x 150 x 8 mm)	<b>Strokes per minute in heavy material</b>	17 spm (3/4" stroke) [Punch Station]
<b>Rectangle Notcher</b>	3" x 5-3/4" x 1/2" (75 x 145 x 12 mm)	<b>Hydraulics</b>	3,500/3,500 psi (241/241 bar)
<b>V-Notch</b>	3" x 3" x 1/2" (75 x 75 x 12 mm)	<b>Motor Standard</b>	10 hp 3 ph (7.46 kW) 230/460 208/380/575
<b>Notching in Leg of Channel</b>	6" to 10" (150 mm to 250 mm)	<b>Motor Optional</b>	10 hp 1 ph (7.46 kW) 230 v
		<b>Dimensions</b>	W-34" (119 cm) L-77-1/4" (174 cm) H-74 1/4" (187 cm)
		<b>Shipping Weight</b>	6,404 lbs. (2,904 kg)



# Optional Standard Tooling

## 6509, 9012, 12012, DO 70, DO 95, DO 120, DO 135, DO 150



12" & 24" Brake



Open End Brake



Pipe Notcher



90° V-Notcher

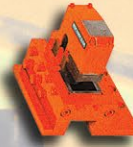

Rectangle Notcher



6" x 6" Die Holder



Channel Shear



Tube Shear



Rod Shear



Picket Tool



Offset Die Holder



Unequal Leg Angle Blades



Strut Shear

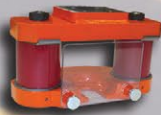

Urethane Stripper

Brake Length Gauge with Scale 12" & 24" Brakes



Brake Table with Scale & Squaring Arm 12" & 24" Brake



48" Back Gauge



Weld Coupon Bender

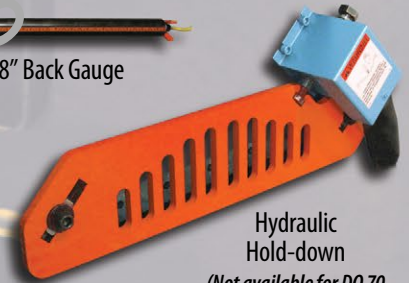

Hydraulic Hold-down (Not available for DO 70 and DO 95)



Multi-Loc Punch Gauging Table 36" and 85" extensions available



Laser Light



Punch Table Extension



Angle Iron Miter Guide



24" x 5' conveyor with angle iron support attached to DO 70/110

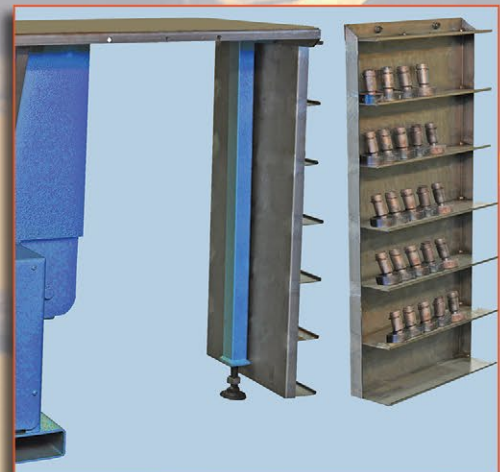

Tool table extension with punch and die storage rack

# FI 8510-20M

## STANDARD FEATURES

- 85-ton punch station (1-1/16" in 1")
- Keyed punch ram for safety
- 10" throat depth
- Punch gauging table with fence and scale
- Die holder complete with 2" die insert
- Punch nut with wrench & stripper
- Adjustable swing-away stripper
- One round punch & die: max. diameter 1-1/4"
- Punch jog control
- Adjustable electric stroke control with scale
- Electric remote foot pedal
- 6" x 6" x 1/2" slug-less angle shear
- 20" flat bar shear
- Shear table with miter fence
- Rod shear capacity 1-1/2" round, 1-1/4" square
- Slug receptacles
- Rectangle notcher capacity: 3" x 5" x 1/2"
- Notcher table with scale and guide
- Two-stage hydraulic pump
- Electrical box supplied with emergency palm button and lock-out tag-out accommodations
- 230/460 volt / 3-ph electrics (must specify voltage)
- All guards necessary to comply with ANSI B 11-5 standards
- Forklift accommodations
- Three-year warranty on parts
- Made in the USA

**SINGLE  
OPERATOR**

**5**

**STATIONS**



## CAPACITIES AND SPECIFICATIONS

RATED ON: A36 MILD STEEL / 65,000 PSI TENSILE

<b>Punching Capacity</b>	85 ton (77 mt) 1-1/16" in 1" (27 mm in 25 mm)	<b>Strut Shear</b>	Samples Required
<b>Special Tooling</b>	4" Max. Dia. (100 mm Max. Dia.)	<b>Rod Shear</b>	1-1/2" (38 mm)
<b>Throat Depth</b>	10" (250 mm)	<b>Round Rod</b>	1-1/4" (32 mm)
<b>Flat Bar Shear</b>	20" Long. (500 mm) 1" x 1/2" (25 x 300 mm) 3/4" x 20" (19 x 500 mm)	<b>Square Rod</b>	
<b>Angle Shear 90° (45° with Bar Shear)</b>	6" x 6" x 1/2" (150 x 150 x 12 mm) 4" x 4" x 1/2" (100 x 100 x 12 mm)	<b>Square Tube Shear</b>	1/2" to 2", 12 gauge (12 mm to 50 mm, 2.75 mm)
<b>Brake 12"</b>	85 ton (77 mt)	<b>Picket Tool</b>	1/2", 3/4" & 1" (12 mm, 19 mm, 25 mm) 16 gauge (1.6 mm)
<b>Brake 24"</b>	85 ton (77 mt)	<b>Weld Coupon Bender</b>	Max. Capacity 2" wide x 0.375" (50.8mm x 9.52mm)
<b>Open End Brake</b>	Max. 1/4" x 5" (6 x 125 mm) Flat or Angle Iron	<b>Offset Die Holder</b>	Max. 40 ton (36 mt)
<b>Pipe Notcher Schedule 40</b>	3/4", 1" (19 mm, 25 mm) 1-1/4" (32 mm) 1-1/2", 2" (38 mm, 50 mm)	<b>Strokes per minute in light material</b>	35 spm (1/4" stroke) [Punch Station]
<b>90° V-Notcher</b>	6" x 6" x 5/16" (150 x 150 x 8 mm)	<b>Strokes per minute in heavy material</b>	14 spm (3/4" stroke) [Punch Station]
<b>Rectangle Notcher 90° V-Notcher</b>	3" x 5" x 1/2" (75 x 125 x 12 mm) 3" x 3" x 1/2" (75 x 75 x 12 mm)	<b>Hydraulics</b>	2,600 psi (183 bar)
<b>Channel Shear</b>	2" to 6" adj. (50 mm to 150 mm adj.)	<b>Motor Standard</b>	5 hp 3 ph (3.76 kW) 230/460 208/380/575
		<b>Motor Optional</b>	5 hp 1 ph (3.76 kW) 230 v
		<b>Dimensions</b>	W-30" (76 cm) L-67" (168 cm) H-77" (195 cm)
		<b>Shipping Weight</b>	4,554 lbs. (2,065 kg)

# DO 8514-20M

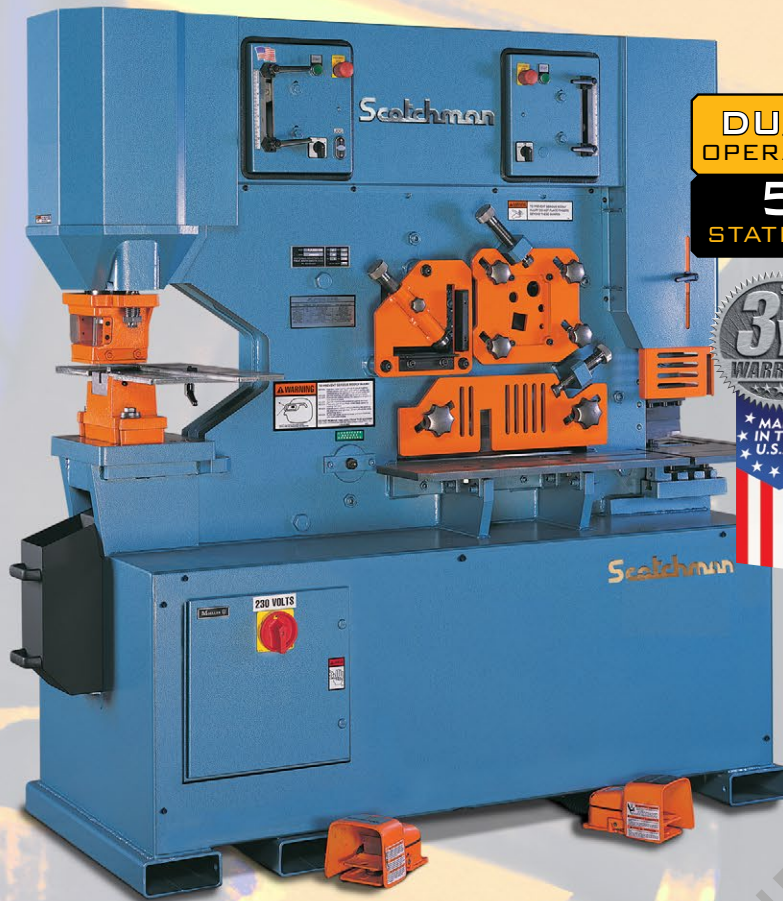

## STANDARD FEATURES

- Dual operator allows for two operators to work at the same time at full capacity
- 85-ton punch station (1-1/16" in 1")
- Keyed punch ram for safety
- 14" throat depth
- Punch gauging table with fence and scale
- Die holder complete with 2" die insert
- Punch nut with wrench & stripper
- Adjustable swing-away stripper
- One round punch & die: max. diameter 1 1/4"
- Punch jog control
- Two adjustable electric stroke controls with scale
- Two electric remote foot pedals
- Two 2-stage hydraulic pumps
- Two valves
- 6" x 6" x 1/2" slug-less angle shear
- Rectangle notcher: 2" x 4" x 1/2" can be converted to 3" x 3" V-Notcher, 50-ton punch station, and 6" open end brake
- 20" flat bar shear
- Shear table with miter fence
- Rod shear: 1/2", 3/4", 1", 1-1/2" round and 1-1/2" square
- Slug receptacles
- Electrical box supplied with emergency palm button and lock-out tag-out accommodations
- 230/460 volt / 3-ph electric (must specify voltage)
- All guards necessary to comply with ANSI B 11-5 standards
- Forklift accommodations
- Three-year warranty on parts
- Made in the USA

## CAPACITIES AND SPECIFICATIONS

RATED ON: A36 MILD STEEL / 65,000 PSI TENSILE

<b>Punching Capacity</b>	85 ton (77 mt) 1-1/16" in 1" (27 mm in 25 mm)	<b>Strut Shear</b>	Samples Required
<b>Special Tooling</b>	4" Max. Dia. (200 mm Max. Dia.)	<b>Rod Shear</b>	
<b>Throat Depth</b>	14" (350 mm)	<b>Round Rod (Max.)</b>	1/2", 3/4", 1", 1-1/2", (13 mm, 19 mm, 25 mm, 38 mm)
<b>Flat Bar Shear</b>	20" Length, (500 mm) 1" x 16", (25 x 400 mm) 3/4" x 20" (19 x 500 mm)	<b>Square Rod (Max.)</b>	1-1/2" (38 mm)
<b>Angle Shear 90° (45° with Bar Shear)</b>	6" x 6" x 1/2" (150 x 150 x 13 mm) 4" x 4" x 1/2" (100 x 100 x 13 mm)	<b>Square Tube Shear</b>	1/2" to 2", 12 gauge (12 mm to 50 mm, 2.75 mm)
<b>Brake 12"</b>	85 ton (77 mt)	<b>Picket Tool</b>	1/2", 3/4" & 1" (13 mm, 19 mm, 25 mm) 16 gauge (1.6 mm)
<b>Brake 24"</b>	85 ton (77 mt)	<b>Weld Coupon Bender</b>	Max. Capacity 2" wide x 0.375" (50.8mm x 9.52mm)
<b>Open End Brake</b>	5" x 5/8" (125 x 16 mm)	<b>Offset Die Holder</b>	Max. 40 ton (36 mt)
<b>Pipe Notcher Schedule 40</b>	3/4", 1" (19 mm, 25 mm) 1-1/4" (32 mm) 1-1/2", 2" (38 mm, 50 mm)	<b>Strokes per minute in light material</b>	48 spm (1/4" stroke) [Punch Station]
<b>90° V-Notcher (Punch Station)</b>	6" x 6" x 5/16" (150 x 150 x 8 mm)	<b>Strokes per minute in heavy material</b>	20 spm (3/4" stroke) [Punch Station]
<b>Rectangle Notcher</b>	2" x 4" x 1/2" (50 x 100 x 13 mm)	<b>Hydraulics</b>	3,350/3,800 psi (231/262 bar)
<b>90° V-Notcher (Notcher Station)</b>	3" x 3" x 1/2" (75 x 75 x 12 mm)	<b>Motor Standard</b>	10 hp 3 ph (7.46 kW) 230/460 208/380/575
<b>Punch Attachment for Notcher Station</b>	50 ton 1-1/4" in 1/2" (32 mm in 12 mm)	<b>Motor Optional</b>	10 hp 1 ph (7.46 kW), 230 v
<b>Throat Depth w/Punch attachment</b>	4-7/16"	<b>Dimensions</b>	W-30" (76 cm) L-70" (178 cm) H-77" (195 cm)
<b>Channel Shear</b>	2" to 6" (50 mm to 150 mm)	<b>Shipping Weight</b>	5,504 lbs. (2,496 kg)



# Optional Standard Tooling

## FI 8510-20M, DO 8514-20M



12" & 24" Brake



Open End Brake



Pipe Notcher



Offset Die Holder



90° V-Notcher



Tube Shear



Picket Tool



6" x 6" Die Holder



Urethane Stripper

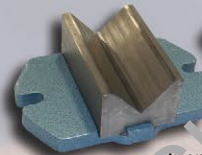

Open End Brake for Notcher End DO 8514



Punch Table Extension



Strut Shear



Channel Shear Blades DO 8514



Weld Coupon Bender



Optional Punch for Notcher End DO 8514



Brake Length Gauge with Scale 12" & 24" Brakes

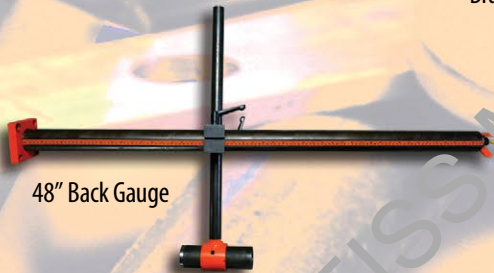

48" Back Gauge



Brake Table with Scale & Squaring Arm 12" & 24" Brake



Multi-Loc Punch Gauging Table 36" & 85" extensions



24" x 5' conveyor with angle iron support attached to FI 8510-20M

Conveyor tables can be lined up to hold longer pieces and still have room for forklift access in between.



Hydraulic Hold-down (FI 8510-20M only)



Laser Light FI-8510-20M ONLY

2.5 FT  
IRONWORKER

WALK PATH 3 FT

CONVEYOR 5 FT

WALK PATH 4 FT

CONVEYOR 5 FT

**SHOP FLOOR SPACE**

19.5 FT

5.5 FT

# ShearMaster 610



SHEAR

## STANDARD FEATURES

- 24" flat bar shear with 4-way reversible blades
- Shear table with miter fence
- Shearing Capacity: 1" x 12", 3/4" x 16", or 1/2" x 24"
- Strokes per minute: Full stroke—12, Half stroke—30
- Hydraulic hold-down
- Electric back gauge
- Electric stroke control
- Electric foot pedal
- Two stage hydraulic pump
- 10 hp motor
- Electric box supplied with emergency palm button and lock-out tag-out accommodations
- 230/460 volt / 3-ph electric (must specify voltage)
- All guards necessary to comply with ANSI B 11-5 Standards
- Dimensions: W-32", L-48", H-70"
- Shipping Weight: 3,065 lbs. (1,370 kg)
- Forklift accommodations
- Three-year warranty on parts
- Made in the USA



*ShearMaster 610 shown with optional 5 ft. Roller Conveyor*

## Optional Standard Tooling

### ShearMaster 610

- Work light
- 10 hp 1 phase motor
- Infeed conveyor
- Advanced feed system for fully automatic production



# In-Stock Punches & Dies

## #20 & #40 Rounds

1/8	11/16
5/32	23/32
3/16	3/4
13/64	25/32
7/32	13/16
1/4	27/32
17/64	7/8
9/32	29/32
5/16	15/16
11/32	31/32
3/8	1
13/32	1-1/32
7/16	1-1/16
15/32	1-3/32
1/2	1-1/8
17/32	1-5/32
9/16	1-3/16
19/32	1-7/32
5/8	1-1/4
21/32	

## #45 Round Punches

1-9/32
1-5/16
1-11/32
1-3/8
1-13/32
1-7/16
1-15/32
1-1/2
1-17/32
1-9/16

## Split Ring Round

1-5/8
1-3/4
2
2-1/4
2-1/2
2-3/4
3

## #49 Round Punches

1-5/8	1-7/8
1-11/16	1-15/16
1-3/4	2
1-13/16	

## Ovals

1/4 x 1/2	13/16 x 1
9/32 x 1/2	7/8 x 1
1/4 x 3/4	15/16 x 1
9/32 x 3/4	1/4 x 1-1/4
5/16 x 3/4	9/32 x 1-1/4
11/32 x 3/4	5/16 x 1-1/4
3/8 x 3/4	3/8 x 1-1/4
13/32 x 3/4	13/32 x 1-1/4
7/16 x 3/4	9/32 x 1-1/4
15/32 x 3/4	5/16 x 1-1/4
1/2 x 3/4	11/32 x 1-1/4
17/32 x 3/4	3/8 x 1-1/4
9/16 x 3/4	13/32 x 1-1/4
19/32 x 3/4	7/16 x 1-1/4
5/8 x 3/4	15/32 x 1-1/4
1/4 x 1	1/2 x 1-1/4
9/32 x 1	17/32 x 1-1/4
5/16 x 1	9/16 x 1-1/4
11/32 x 1	19/32 x 1-1/4
3/8 x 1	5/8 x 1-1/4
13/32 x 1	21/32 x 1-1/4
7/16 x 1	11/16 x 1-1/4
15/32 x 1	23/32 x 1-1/4
1/2 x 1	3/4 x 1-1/4
17/32 x 1	25/32 x 1-1/4
9/16 x 1	13/16 x 1-1/4
19/32 x 1	7/8 x 1-1/4
5/8 x 1	15/16 x 1-1/4
21/32 x 1	7/16 x 1-1/2
11/16 x 1	9/16 x 1-1/2
23/32 x 1	11/16 x 1-1/2
3/4 x 1	13/16 x 1-1/2
25/32 x 1	15/16 x 1-1/2

## Squares

1/4
9/32
5/16
11/32
3/8
13/32
7/16
15/32
1/2
17/32
9/16
19/32
5/8
21/32
11/16
23/32
3/4
25/32
13/16
27/32
7/8
29/32
1
1-1/32

## Hexagon

1/2
17/32
11/16
3/4

## Corner Turning

1/2
3/4

## Trimming & Cut Off

3/4
1

## Round Metric

5 mm	19 mm
6 mm	20 mm
7 mm	21 mm
8 mm	22 mm
9 mm	23 mm
10 mm	24 mm
11 mm	25 mm
12 mm	26 mm
13 mm	27 mm
14 mm	28 mm
15 mm	29 mm
16 mm	30 mm
17 mm	31 mm
18 mm	32 mm

## Round Offset Dies

9/32
5/16
11/32
3/8
13/32
7/16
15/32
1/2
17/32
9/16
19/32

## #40 Punch

1/8" Thru 1-1/4"  
3 mm Thru 31 mm

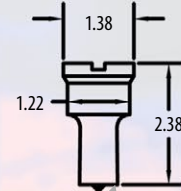

## #45 Punch

1-9/32" Thru 1-9/16"  
32 mm Thru 36 mm

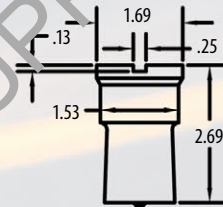

## #49 Punch

(12012, DO 120, DO 135, DO 150 Machines Only)  
1-5/8" Thru 2"  
37 mm Thru 52 mm

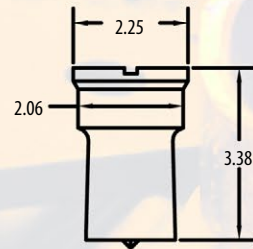

## Split Ring Punch

Thru 4"

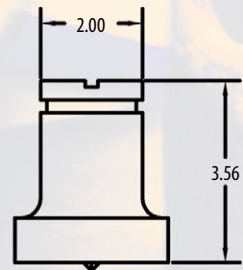

## #20 Punch

1/8" Thru 2-1/4"  
3 mm Thru 57 mm

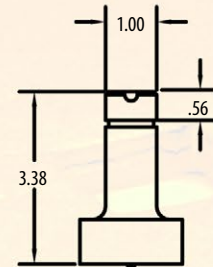



# Special Punches & Dies

**#82 Die**

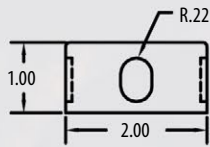

**#86 Die**

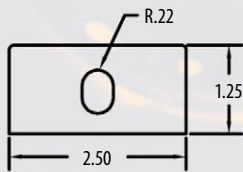

**3" Die**

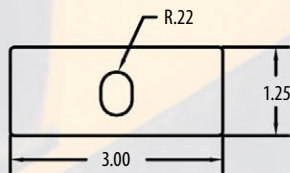

**6 x 6 Die**

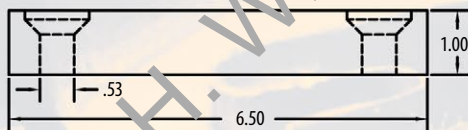

**#20 Die**

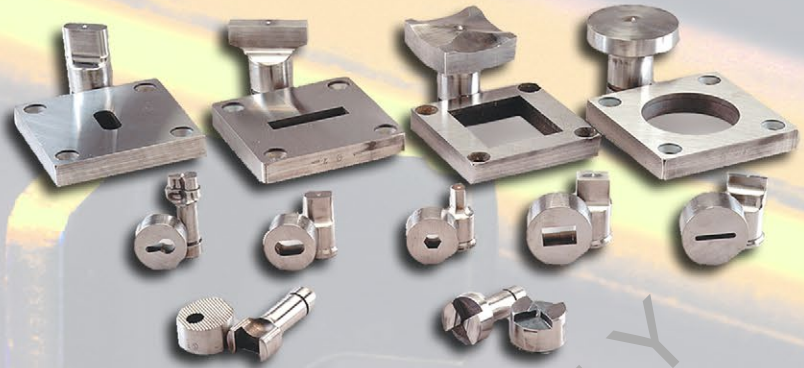
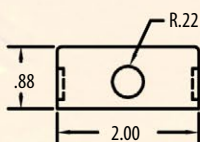

## CUSTOM TOOLING

Various tooling options and hundreds of punches and dies are available for every model. In addition, we build custom tooling for your special applications.

Sample Custom Tooling Built for Special Applications

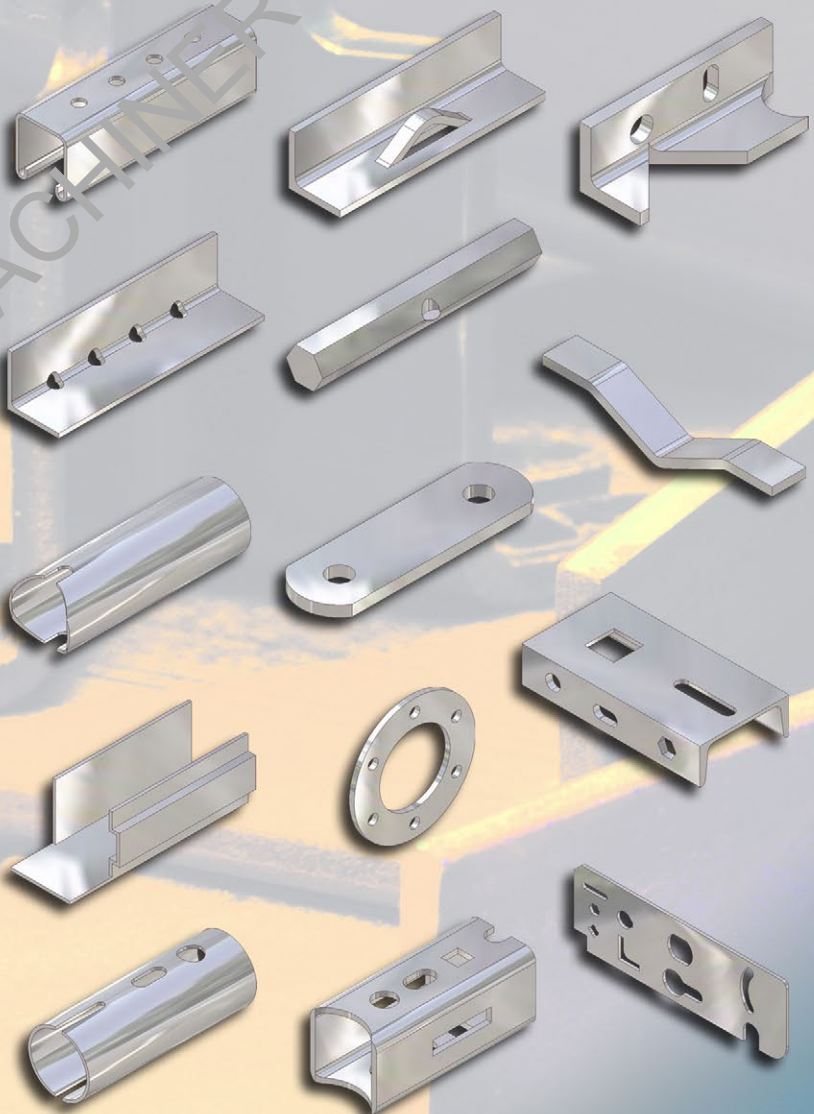

# CPO 275 Series

## STANDARD EQUIPMENT & FEATURES

- Double self-centering vise assures burr-free cuts
- Miter capabilities 45° left to 45° right
- Capable of slotting
- Two cutting speeds
- Hardened and ground worm and wheel gear box
- Worm wheel of top quality bronze
- Chip drawer
- Seven-gallon coolant tank with pump
- One 250 mm HSS blade
- One blade wrench
- One gallon concentrated coolant
- 230 or 460 volt/3-ph electric (must specify voltage)
- Three-year warranty on parts
- Made in the USA

## MAXIMUM CAPACITIES (WITH A 275 MM/10-3/4" BLADE)

Tube	90 Degree	45 Degree
Round	3-3/8" (86 mm)	2" (51 mm)
Square	3" x 3" (76 x 76 mm)	2" x 2" (51 x 51 mm)
Rectangle	3" x 2-3/8" (76 x 60 mm)	2" x 2" (51 x 51 mm)

Tube	90 Degree	45 Degree
Round	1-1/2" (38 mm)	1" (25 mm)
Square	1-1/2" x 1-1/2" (38 x 38 mm)	1" x 1" (25 x 25 mm)



COLD SAWS

## CPO 275

### MANUAL SAW

- Manual clamp for material vise
- Operator controlled trigger switch
- Miter locking device stops 45° left, 90° and 45° right

## CPO 275 PK

### MANUAL SAW WITH POWER CLAMP

- Air-operated clamp for material vise
- Operator controlled trigger switch

## CPO 275 PKPD

### SEMI-AUTOMATIC SAW

- Air-operated clamp for material vise
- Pneumatic power down feed with electric controls
- Emergency stop button



## SPECIFICATIONS

### Cutting Speeds (must specify when ordering)

**LT** (Low Turn) designed for solid mild steel, solid stainless steel & thick wall pipe

LT 30/60 rpm

**HT** (High Turn) designed for thin wall tube .060 wall thickness or thinner and non-ferrous material

HT 60/120 rpm

**SS** (Single Speed) designed for 220 1-ph applications

SS 60 rpm

**Factory Wired:** Specify 208 3-ph, 230 3-ph, 460 3-ph, 575 3-ph 60 Hz, or 220 1-ph (SS Model Only)

**Maximum Diameter Blade:** 275 mm

**Arbor Bore:** 1-1/4" (32 mm)

**Width:** 21-7/8"

**Depth:** 43-1/2"

**Height:** (not incl. feed handle) 53-1/4"

**Shipping Weight:**

CPO 275: 550 lbs. (279 kg)

CPO 275 PK: 580 lbs. (263 kg)

**Pin Spacing:** 2/8/45

**Height:** (from floor to vise) 36-1/8"

CPO 275 PKPD: 670 lbs. (303 kg)



**MAXIMUM CAPACITIES  
(WITH A 350 MM/13-7/8" BLADE)**

Tubing	90 Degree	45 Degree
Round	4-1/2" (114 mm)	4" (102 mm)
Square	4-1/4" x 4-1/4" (108 x 108 mm)	3-3/4" x 3-3/4" (96 x 96 mm)
Rectangle	5-1/2" x 4" (140 x 102 mm)	3-3/4" x 3-3/4" (96 x 96 mm)
Solid	90 Degree	45 Degree
Round	2" (51 mm)	1-3/4" (44 mm)
Square	2" x 2" (51 x 51 mm)	1-3/4" x 1-3/4" (44 x 44 mm)

# CPO 350 Series

**STANDARD EQUIPMENT & FEATURES**

- Double self-centering vise assures burr-free cuts
- Miter capabilities 45° left to 45° right
- Miter locking device: quick, accurate setting-stops at 45° left, 90° and 45° right
- Capable of slotting
- Two cutting speeds
- Double reduction, hardened and ground worm and wheel gear box
- Worm wheel of top quality bronze
- Chip drawer
- Seven-gallon coolant tank with pump
- One 315 mm HSS blade
- One blade wrench
- One gallon concentrated coolant
- 230 or 460 volt/3-ph electric (must specify voltage)
- Three-year warranty on parts
- Made in the USA

## CPO 350

**MANUAL SAW**

- Manual clamp for material vise
- Operator controlled trigger switch

## CPO 350 PK

**MANUAL SAW WITH POWER CLAMP**

- Air-operated clamp for material vise
- Operator controlled trigger switch

## CPO 350 PKPD

**SEMI-AUTOMATIC SAW**

- Air-operated clamp for material vise
- Pneumatic power down feed with electric controls
- Emergency stop button



**SPECIFICATIONS**

**Cutting Speeds (must specify when ordering)**

**LT** (Low Turn) designed for solid mild steel, solid stainless steel & thick wall pipe

LT 22/44 rpm

**HT** (High Turn) designed for thin wall tube .060 wall thickness or thinner and non-ferrous material

HT 44/88 rpm

**VS** Variable Speed Drive 11 to 177 rpm, wired 230/460 3-ph

**VS** Variable Speed Drive 11 to 177 rpm, wired 220 1-ph

**SS** (Single Speed) designed for 220 1-ph applications

SS 44 rpm

**Motor Rate:** 3 hp

**Motor Rate:** 2.5 hp

**Motor Rate:** 5 hp

**Motor Rate:** 5 hp

**Motor Rate:** 3 hp

**Factory Wired:** Specify 208 3-ph, 230 3-ph, 460 3-ph, 575 3-ph 60 Hz or 220 1-ph 60 Hz (SS model only)

**Maximum Diameter Blade:** 350 mm

**Arbor Bore:** 1-9/16" (40 mm)

**Width:** 21-7/8"

**Depth:** 43-1/2"

**Height:** (not incl. feed handle) 56-1/4"

**Shipping Weight:**

CPO 350 LT: 660 lbs. (299 kg)

CPO 350 PK: 660 lbs. (299 kg)

**Pin Spacing:** 4/12/64

**Height:** (floor to vise) 37-7/16"

CPO 350 PKPD: 760 lbs. (344 kg)

# CPO 350 NF Series

## STANDARD EQUIPMENT & FEATURES

- Double self-centering vise assures burr-free cuts
- Miter capabilities 45° left to 45° right
- Miter locking device: quick, accurate setting-stops at 45° left, 90°, and 45° right
- Capable of slotting
- Positive cog belt driven
- Chip drawer
- One-gallon coolant tank with mist lubrication system
- One 350 mm carbide-tipped blade
- One blade wrench
- One gallon coolant
- 230 or 460 volt/3-ph electric (must specify voltage)
- Three-year warranty on parts
- Made in the USA

## MAXIMUM CAPACITIES (WITH A 350 MM/13-7/8" BLADE)

Tubing	90 Degree	45 Degree
Round	4-1/2" (114 mm)	4-1/4" (108 mm)
Square	4-1/4" x 4-1/4" (108 x 108 mm)	4" x 4" (102 x 102 mm)
Rectangle	5-1/2" x 4" (140 x 102 mm)	4" x 4" (102 x 102 mm)
Solid	90 Degree	45 Degree
Round	3" (76 mm)	2-1/2" (64 mm)
Square	3" x 3" (76 x 76 mm)	2-1/2" x 2-1/2" (64 x 64 mm)



COLD SAWS

## CPO 350 NF PKPD

### SEMI-AUTOMATIC SAW

- Air-operated clamp for material vise
- Pneumatic power down feed with electric controls
- Emergency stop button

## CPO 350 NF PK

### MANUAL SAW WITH POWER CLAMP

- Air-operated clamp for material vise
- Operator controlled trigger switch

## CPO 350 NF

### MANUAL SAW

- Manual clamp for material vise
- Operator controlled trigger switch



## SPECIFICATIONS

*Non-Ferrous machines designed for aluminum, plastic, copper, etc.*

<b>Cutting Speeds:</b>	3,000 rpm		
<b>Motor Rate:</b>	5 hp		
<b>Factory Wired:</b>	Specify 208 3-ph, 230 3-ph, 460 3-ph, or 575 3-ph 60 Hz		
<b>Maximum Diameter Blade:</b>	350 mm		
<b>Arbor Bore:</b>	1-9/16" (40 mm)		
<b>Pin Spacing:</b>	4/12/64		
<b>Width: 21-7/8"</b>	<b>Depth: 43-1/2"</b>	<b>Height: (not incl. feed handle) 56-1/4"</b>	<b>Height: (from floor to vise) 37-7/16"</b>
<b>Shipping Weight:</b>	CPO 350 NF: 625 lbs. (283 kg)	CPO 350 NF/PK: 650 lbs. (294 kg)	CPO 350 NF/PK/PD: 725 lbs. (328 kg)



# Cold Saw Options

**60" or 120" Material  
Stop Roller Conveyor  
Mounted with an  
Advanced Measuring  
Quick-Loc System**

Designed for quick, easy and accurate length setting. Available left to right or right to left material feed.

**Right-Hand Quick Loc  
with Quick Release  
Handle Mounted on a  
Roller Conveyor**

**Scale 1/16"  
Increments**

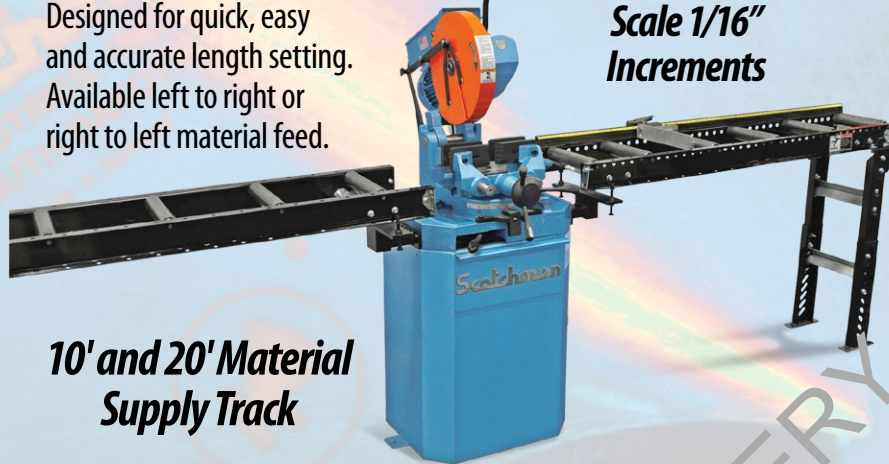

**10' and 20' Material  
Supply Track**

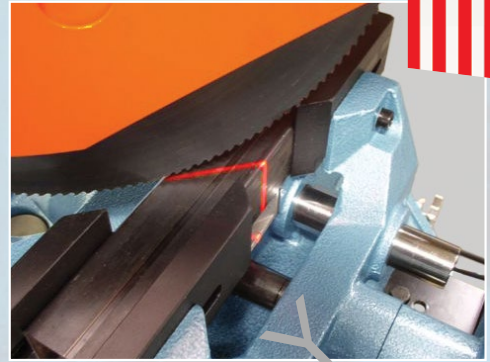

**Blade Guide Laser Light**

**SPECIAL NOTE**

For customer using single phase power: the variable speed allows 3-ph machine to operate with 220 volt, 1-ph power without loss of power.

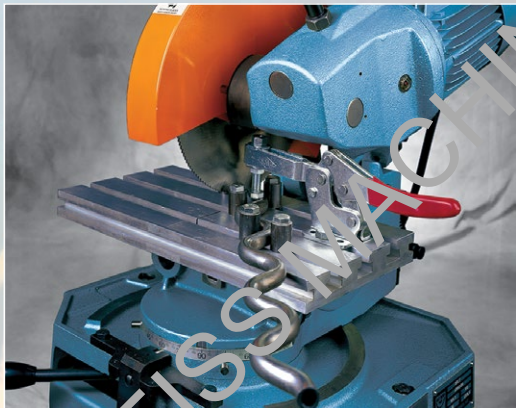

**Special Clamping Fixture**

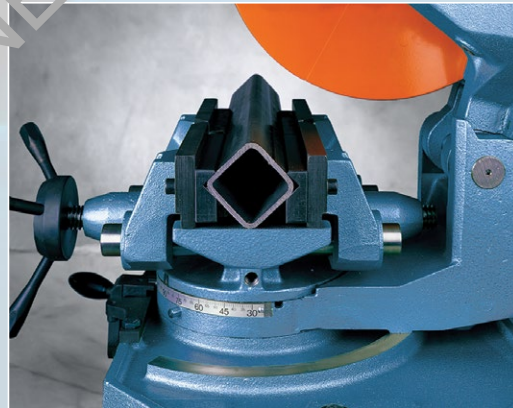

**Square Tube Jaws**



**Variable Speed Control**

Recommended for cutting multiple shapes, sizes, and thicknesses. RPM can be fine-tuned to achieve optimum blade speed for each application and increase blade life.

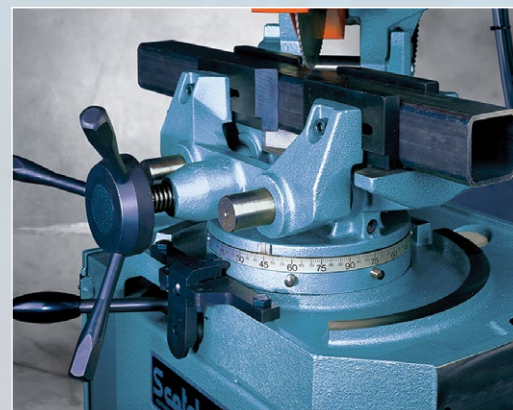

**Miter Locking Device**

**STANDARD FEATURE**  
(not available for 275 PK or 275 PKPD models)

# Upcut Circular Cold Saw



## SUP-500 NF

## SUP-600 NF

### MAXIMUM CAPACITIES

(WITH A MAXIMUM 500 MM OR 20" DIAMETER BLADE)

(WITH A MAXIMUM 600 MM OR 24" DIAMETER BLADE)

	90 Degree		45 Degree	
Round	7"	180 mm	7"	180 mm
Square	6"	150 mm	4-3/4"	120 mm
Rectangle	11-3/4" x 5"	300 x 125 mm	5-3/4" x 4-3/4"	145 x 120 mm

	90 Degree		45 Degree	
Round	9"	230 mm	9"	230 mm
Square	8"	203 mm	7"	177 mm
Rectangle	15" x 6"	381 x 152 mm	10" x 4"	250 x 100 mm

### CUTTING DIAGRAM

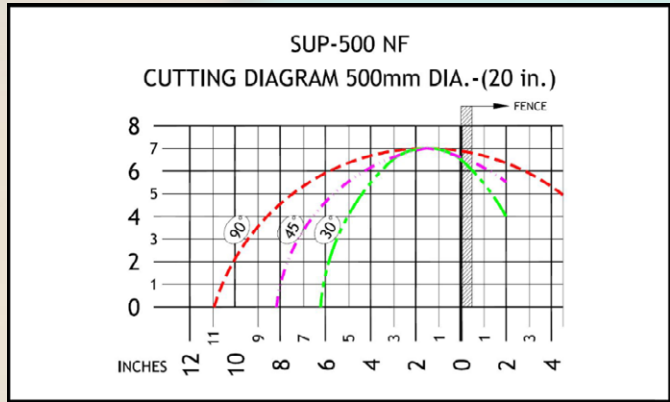

### CUTTING DIAGRAM

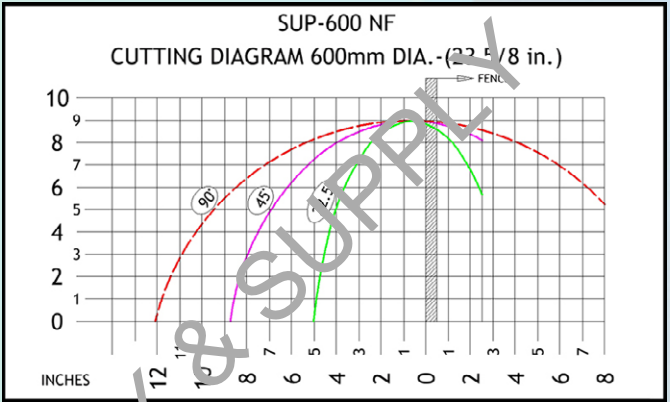

COLD SAWS



### STANDARD EQUIPMENT & FEATURES

- Precision Miter Upcut non-ferrous Saw
- Safety Hood with Safety Switch that will not allow Saw to run with Hood Open
- Power Hood (SUP-600 NF)
- Blade Door with Safety Interlock Switch
- Dual Palm Buttons
- Adjustable Feed Rate on Saw Head
- Two Horizontal Pneumatic Clamps
- Two Vertical Pneumatic Clamps
- Miter Capability
- Capable of Slotting
- Moveable Back Fence for Larger Capacity
- One Gallon Coolant
- Coolant Tank with Mist Lubrication
- One 20" (500 mm) diameter, 120-tooth Carbide Blade (SUP-500 NF)
- One 24" (600 mm) diameter, 132-tooth Carbide Blade (SUP-600 NF)
- One Blade Wrench
- Air Hose
- Chip Collection Drawer in Base and 4-3/4" Chip Collection Port
- Adjustable Leveling Pads
- 230 or 460 volt/3-ph electric, (must specify voltage)
- Three-year Warranty on Parts
- Made in Spain

### SPECIFICATIONS

**Non-Ferrous Upcut Saw designed for aluminum, PVC, copper, etc.**

	SUP-500	SUP-600
<b>Cutting Speeds:</b>	3,000 RPM	3,000 RPM
<b>Motor Rate:</b>	5.5 hp	5.5 hp
<b>Factory Wired:</b>	Specify 230 3-ph or 460 3-ph for both	
<b>Maximum Diameter Blade:</b>	20" (500 mm)	24" (600 mm)
<b>Arbor Bore:</b>	1.97" (50 mm)	1.97" (50 mm)
<b>Width:</b>	47-1/4"	51-1/4"
<b>Depth:</b>	43-3/8"	48"
<b>Height (top of the hood):</b>	60-1/4"	64-3/8"
<b>Height (from floor to vise):</b>	38 5/8" (970mm)	
<b>Shipping Weight:</b>	1,200 lbs. (544 kg)	1,465 lbs. (665 kg)



# SUP-600 ANGLEMASTER

## MAXIMUM CAPACITIES (WITH A MAXIMUM 600 MM OR 24" DIAMETER BLADE)

	90 Degree		45 Degree	
Round	8"	203 mm	7"	177 mm
Square	7"	178 mm	6"	152 mm
Rectangle	9" x 5"	228 x 127 mm	7" x 4-3/4"	178 x 120 mm

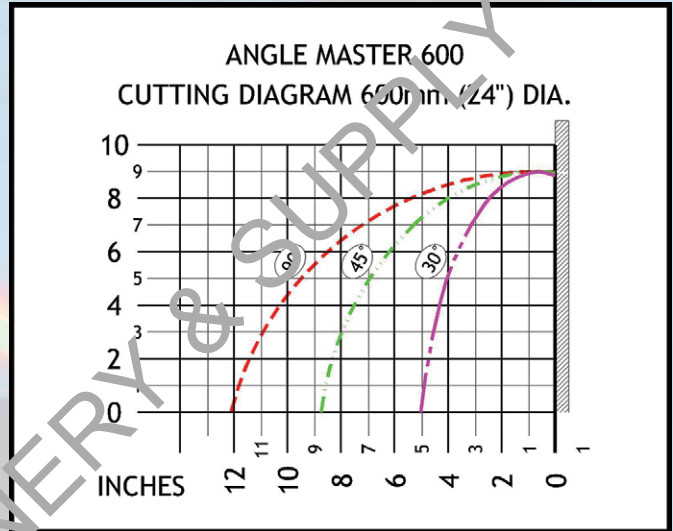

### SPECIFICATIONS

**Non-Ferrous Upcut Saw designed for aluminum, PVC, copper, etc.**

	<b>SUP-600</b>
<b>Cutting Speeds:</b>	3,000 RPM
<b>Motor Rate:</b>	5.5 hp
<b>Factory Wired:</b>	Specify 230 Volt or 460 3-ph
<b>Maximum Diameter Blade:</b>	24" (600 mm)
<b>Arbor Bore:</b>	1.97" (50 mm)
<b>Width:</b>	51-1/4"
<b>Depth:</b>	48"
<b>Height (top of the hood):</b>	61-3/8"
<b>Height (from floor to vise):</b>	38 5/8" (970mm)
<b>Shipping Weight:</b>	1,465 lbs. (665 kg)

### STANDARD EQUIPMENT & FEATURES

- The AngleMaster System Push Feeds your Stock to the Miter Saw which is Automatically Rotated to the Angle Designated for your Part.
- Feed Available - 10' to 30'
- Right to Left Feed Only
- Touch Screen Controls
- Software (Includes Profile Screen)
- Job Storage
- Precision Miter Upcut non-ferrous Saw
- Powered Safety Hood with Safety Switch that will not allow Saw to run with Hood Open
- Blade Door with Safety Interlock Switch
- Dual Palm Buttons
- Adjustable Feed Rate on Saw Head
- Two Horizontal Pneumatic Clamps
- Two Vertical Pneumatic Clamps
- Miter Capability
- Capable of Slotting
- One Gallon Coolant
- Coolant Tank with Mist Lubrication
- One 24" (600 mm) diameter, 132-tooth Carbide Blade (SUP-600 NF)
- One Blade Wrench
- Air Hose
- Chip Collection Drawer in Base and 4-3/4" Chip Collection Port
- Adjustable Leveling Pads
- 230 or 460 volt/3-ph electric, (must specify voltage)
- Two-year Warranty on Parts (SUP Saw)
- One-year Warranty on Parts (Angle Master)
- Saw Made in Spain / AngleMaster Made in Ames, IA

## V-460 CHIP VACUUM

The V-460 Chip Vacuum is ideal for collecting steel, dust, aluminum and plastic shavings.

### STANDARD FEATURES

- 27 Gallon Storage Container on Wheels, with Quick-Release Handle
- Air Filter Shaker Turbine
- 2.4 hp motor
- 706 CFM Air Flow through 1-4.5" inlet
- Shipping Weight: 330 lbs. (150 kg)





# GAA-500-90 Automatic Upcut Circular Cold Saw

**Saw for non-ferrous cutting--Shuttle feed design for straight 90° cuts on large diameter profiles.**



### STANDARD EQUIPMENT & FEATURES

- Automatic Cycle
- Semi-automatic or Automatic Operation
- Automatic Feeder, 20 inches x 2 Strokes (20" + 20" Max.) Double Advance
- Powered Hood Lift
- Emergency Stop
- Adjustable Cutting & Feeding Speeds
- Adjustable Length Selector from .200 to 20"
- Three Horizontal Pneumatic Clamps
- Three Vertical Pneumatic Clamps
- Miter Capability 90°
- Pneumatic Lubrication System with Spray
- One Gallon Coolant
- Coolant Tank with Mist Lubrication
- Mist Coolant Pump
- One 20" (500 mm) Diameter Carbide Blade
- One Blade Wrench
- Air Hose
- Base Designed as a Chip Collection with Two Chip Extraction Ports
- Adjustable Leveling Pads
- 230 or 460 volt/3-ph electric, (must specify voltage)
- Two Year Warranty on Parts
- Made in Spain

COLD SAWS

**GAA-500-90 with DT20 (Optional Drill)**



### CUTTING DIAGRAM

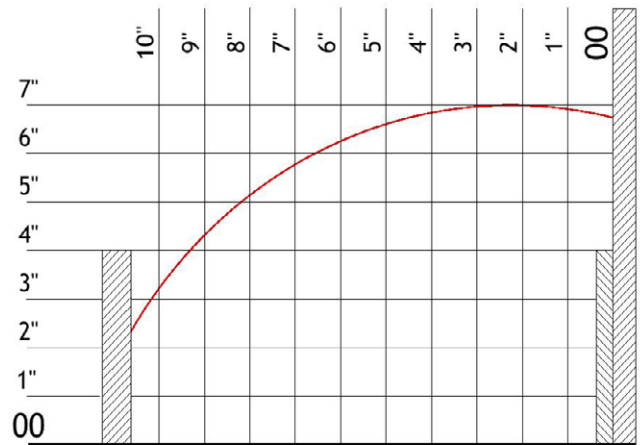

CUTTING CAPACITY- Ø500mm (20") BLADE

**GAA-500-90**

### SPECIFICATIONS

**Non-Ferrous Upcut Saw designed for aluminum, PVC, copper, etc.**

- Length Tolerance:** + or - 0.006" per index
- Cutting Speeds:** 3,000 RPM
- Motor Rate:** 7.5 hp
- Motor Rate:** 7.5 hp
- Factory Wired:** Specify 230 3-ph or 460 3-ph
- Maximum Diameter Blade:** 20" (500 mm)
- Arbor Bore:** 1.97" (50 mm)
- Width: 77" Depth: 42" Height:** (top of Hood) 39"
- Height:** (from floor to vise) 38 5/8" (970 mm)
- Shipping Weight:** 1680 lbs. (762 kg)

	90 Degree	
Round	6"	150 mm
Square	6" x 6"	150 x 150 mm
Rectangle	10" x 3"	250 x 75 mm

# CPO 315 HFA Series



## CPO 315 HFA

**Hitch Feed Automatic**

- Available in ferrous and non-ferrous models

### STANDARD EQUIPMENT & FEATURES

- Fully Automatic Cycle
- Push Button Controls actuate the Complete Cycle
- 5 hp Variable rpm Speed Control (ferrous model)
- 5 hp 3,000 rpm (non-ferrous model)
- Interlocking Safety Hood
- Clamping both sides of Blade - Highest Quality, Burr-Free Cuts
- Blade Guides for Accurate Tolerances (ferrous model)
- Mist Coolant
- Adjustable Stroke Control on the Saw Head
- Adjustable Down Feed Control on the Saw Head for Feed Rate
- Piece Counter
- Length Scale in both Inches and Metric
- Quick and Easy Fine Adjustment of Length Setting
- One Saw Blade
- One Gallon Concentrated Coolant
- Two-year Warranty on Parts
- Made in the USA

### OPTIONAL EQUIPMENT

- Flood Coolant
- Form Jaws for Multiple Tubes
- Digital Read-out for Quick Easy Length Setting
- Ten-foot or Twenty-foot Material Supply Track

### CUTTING CAPACITIES

BASED ON MILD STEEL

#### Tubing

- Round up to 3-1/2" ( $\leq 89$  mm)
- Square up to 3-1/8" x 3-1/8" ( $\leq 79$  mm)

#### Solid

- Round up to 1-3/4" ( $\leq 44.5$  mm)
- Square up to 1-1/2" x 1-1/2" ( $\leq 37$  x 37 mm)
- (NF Saw) up to 3-1/2" ( $\leq 89$  mm)

### CUTTING SPEEDS

- CPO 315 HFA Variable Speed 11 to 177 rpm
- CPO 315 HFA NF 3,000 rpm

### SPECIFICATIONS

- Length Tolerance:** + or - 0.006 per index
- Squareness Tolerance:** + or - 0.002 per diameter inch
- Minimum Cut Length:** 1/8"
- Maximum Cut Length:** Single Index 30", Double Index 60", Triple Index 90"
- Motor HP Ferrous Models:** 5 hp
- Motor HP Non-Ferrous Models:** 5 hp
- Power Supply:** 208/230/460 3-ph (must specify voltage)
- Air Pressure:** 90 lbs. minimum
- Maximum Saw Blade Diameter:** 315 mm
- Arbor Bore Size:** 40 mm
- Pin Spacing:** 4/12/64
- Length:** 100"      **Width:** 44"      **Height:** 64"      **Shipping Weight:** 1,770 lbs. (802 kg)

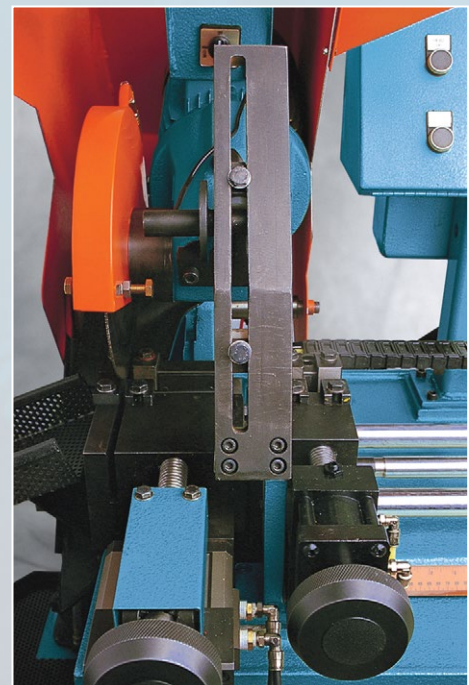

**Stroke Control Adjustment**



# CPO 315 HFA CNC

## Hitch Feed Automatic

- Available in ferrous and non-ferrous models

## STANDARD EQUIPMENT & FEATURES

- Fully Automatic Cycle
- Touch Screen Controls
- 5 hp Variable rpm Speed Control (ferrous model)
- 5 hp 3,000 rpm (non-ferrous model)
- Interlocking Safety Hood
- Clamping both sides of Blade--Highest Quality, Burr-Free Cuts
- Blade Guides for Accurate Tolerances (ferrous model)
- Mist Coolant
- Adjustable Stroke Control on the Saw Head
- Adjustable Down Feed Control on the Saw Head for Feed Rate
- Fast Length Setup
- No Wrenches required to Set Length
- Adjustable Indexing Feed Speeds
- Program up to four Separate Cut Lengths in each Job
- 100 Program Job Storage
- 30" Single Length Shuttle
- Unlimited Shuttles
- Piece Counter
- One Saw Blade
- One Gallon Concentrated Coolant
- Two-year Warranty on Parts
- Made in the USA



COLD SAWS

## CUTTING CAPACITIES - BASED ON MILD STEEL

<b> tubing</b>	
Round	up to 3-1/2" (≤ 89 mm)
Square	up to 3-1/8" x 3-1/8" (≤ 79 mm)
<b> Solid</b>	
Round	up to 1-3/4" (≤ 44.5 mm)
Square	up to 1-1/2" x 1-1/2" (≤ 37 x 37 mm)
(NF Saw)	up to 3-1/7" (≤ 89 mm)

## OPTIONAL EQUIPMENT

- Flood Coolant
- Form Jaws for Multiple Tubes
- Ten-foot or Twenty-foot Material Supply Track

## CUTTING SPEEDS

CPO 315 HFA	Variable Speed 11 to 177 rpm
CPO 315 HFA NF	3,000 rpm

## SPECIFICATIONS

- Length Tolerance:** + or - 0.006" per index
- Squareness Tolerance:** + or - 0.002 per diameter inch
- Motor HP:** 5 hp
- Power Supply:** 208/230/460 volt, 3-ph (must specify voltage)
- Air Pressure:** 90 lbs. minimum
- Maximum Saw Blade Diameter:** 315 mm
- Arbor Bore Size:** 40 mm
- Pin Spacing:** 4/12/64
- Length:** 72"      **Width:** 44"      **Height:** 64"      **Shipping Weight:** 1,770 lbs. (802 kg)

# CPO 315 RFA Series

*Scotchman Roller Feed Automatics are designed to your specifications*



GOLD SAWS

## STANDARD EQUIPMENT & FEATURES

- Fully Automatic Cycle
- Touch Controls actuate the Complete Cycle
- Automatic Loading of each New Bar
- Automatic Trim cut of each New Bar
- Automatic Tube Ejection
- Clamping both sides of Blade - Highest Quality, Burr-Free Cuts
- 5 hp Variable rpm Speed Control (ferrous model)
- 5 hp - 3,000 rpm (non-ferrous model)
- Interlocking Safety Hood
- Blade Guides for Accurate Tolerances (ferrous model)
- Trim and Remnant Gate
- Adjustable Stroke Control on the Saw Head for Feed Rate
- Piece Counter
- Length Scale in both Inches and Metric
- Digital Read-out for Quick and Easy Fine Adjustment of Length Setting
- Supply Table takes up to 24' Material
- Mist Coolant System
- One Saw Blade
- One Gallon Concentrated Coolant
- Two-year Warranty on Parts
- Made in the USA

## OPTIONAL EQUIPMENT

- In-line Deburring Unit
- Flood Coolant
- Longer Cut Lengths - 90" or 120"
- Bundle Loader Magazine

## CUTTING CAPACITIES

- BASED ON MILD STEEL

Round Tube	3" (76 mm)
Round Solid	1-3/4" (44.5 mm)
Square Tube	3" x 3" (76 x 76 mm)
Square Solid	1-1/2" x 1-1/2" (37 x 37 mm)

## CPO 315 RFA/ST

**Fully Automatic Roller Feed Saw shown with Supply Track**

- Available in ferrous and non-ferrous models



**315 RFA Bundle Loading Magazine**

## SPECIFICATIONS

- Length Tolerance:** + or - 0.006 repeatability
- Minimum Cut Length:** 1-1/4"
- Maximum Cut Length:** 60" (90" or 120" available)
- Minimum Trim Cut:** 1"
- Motor HP Ferrous Models:** 5 hp
- Motor HP - Non-ferrous Model:** 5 hp
- Power Supply:** 208/230/460 3-ph (must specify voltage)
- Air Pressure:** 90 lbs. minimum
- Squareness Tolerances:** + or - 0.002 per diameter inch
- Maximum Saw Blade:** 315 mm
- Arbor Bore Size:** 40 mm
- Pin Spacing:** 4/12/64
- Supply Table Maximum Raw Stock:** 24'
- Supply Table Width:** 24"
- Length:** 384"      **Width:** 46"
- Height:** 63"      **Shipping Weight:** 2,745 lbs. (1,245 kg)

## CUTTING SPEEDS

- CPO 315 RFA/ST**      Variable Speed 11 to 177 rpm
- CPO 315 RFA/ST NF**      3,000 rpm

# Circular Cold Saw Blades • Blade Sharpening



**Scotchman offers a fast, high-quality Blade Sharpening Service and will grind blades with special tooth number.**

**Scotchman has a complete selection of saw blades *in stock for immediate delivery.***

COLD SAWS

**250 mm-10" HSS-DM05  
32 mm BORE  
2/8/45 & 2/11/63 Pin Spacing**

PART NO.	THICKNESS	TEETH
74300	.080	90
74304	.080	100
74302	.080	120
74306	.080	150
74305	.080	180
74307	.080	240

**275 mm-10-3/4" HSS-DM05  
32 mm BORE  
2/8/45 & 2/11/63 Pin Spacing**

PART NO.	THICKNESS	TEETH
74360	.080	90
74361	.080	100
74362	.080	120
74363	.080	150
74365	.080	180
74366	.080	220
74367	.080	260

**CARBIDE-TIPPED FOR NON-FERROUS MODELS**

**Non-Ferrous Standard Cold Saw Blades  
40 mm BORE 2/8/55 & 4/12/64 Pin Spacing**

PART NO.	THICKNESS	DIAMETER	TEETH
74326	.085	12"	120 Carbide
74327	.125	12"	72 Carbide
74329	.125	13-1/2"	84 Carbide

**50 mm BORE 2/15/80 Pin Spacing**

PART NO.	THICKNESS	DIAMETER	TEETH
74490	.161	20"	80 Carbide
74495	.161	20"	96 Carbide
74500	.161	20"	120 Carbide
74505	.177	24"	72 Carbide
74510	.177	24"	132 Carbide

**275 mm-10-3/4" HSS-DM05  
40 mm BORE  
2/8/55 & 4/12/64 Pin Spacing**

PART NO.	THICKNESS	TEETH
74309	.100	90
74308	.100	100
74310	.100	120
74311	.100	150
74312	.100	180
74313	.100	220
74314	.100	260

**315 mm-12-1/2" HSS-DM05  
40 mm BORE  
2/8/55 & 4/12/64 Pin Spacing**

PART NO.	THICKNESS	TEETH
74355	.100	90
74356	.100	100
74357	.100	110
74345	.100	120
74348	.100	150
74350	.100	180
74352	.100	220
74354	.100	280

**350 mm-14" HSS-DM05  
40 mm BORE  
2/8/55 & 4/12/64 Pin Spacing**

PART NO.	THICKNESS	TEETH
74390	.100	90
74391	.100	100
74392	.100	110
74393	.100	120
74394	.100	150
74395	.100	180
74396	.100	220
74397	.100	280

**POWER 2000 Blades • 315 mm 12-1/2"-DM05  
40 mm BORE 2/8/55 & 4/12/64 Pin Spacing**

PART NO.	THICKNESS	TEETH
074372	.070	ALL

**Blades are coated for longer blade life.  
Maximum wall thickness .100**

**PERFORMANCE 3000 Blades • 315 mm 12-1/2"-DM05  
40 mm BORE 2/8/55 & 4/12/64 Pin Spacing**

PART NO.	THICKNESS	TEETH
074349	.100	ALL

**Blades are coated for longer blade life.**



# Scotchman Automation Systems

## RG DIGITAL QUICK STOP

This Digital Quick Stop is an entry level programmable stop. It is priced right, yet very durable. Setup is as easy as entering the desired cut length and press go. It can be mounted to move left to right OR right to left. Available in 8' and 12' lengths.

## RG STOP/PUSHER SYSTEM

The Stop/Pusher system can be used as a "go to" stop or as a semi-automatic push feed system. It uses Windows-based technology w/ touch screen controls. The system can be mounted to feed left to right OR right to left. Available in lengths from 8' to 30'.

## RG AUTO FEED SYSTEM (AFS)

The RG Auto Feed System can be added to Scotchman's CPO 350 PK/PD and SUP series of upcut saws to make a full automatic cutting saw. The RG-AFS will give you the best of both worlds, by making your Scotchman capable of cutting angle cuts in semi-auto mode and then using the RG as a stop length gauge. When cutting your lists of straight cuts, use the RG as an automatic push feed, letting the system do all the thinking for you. This system has the ability to cut a combination of multiple lengths or cut a run of all the same length. Save your different cut jobs using the large storage space on the Windows based PC. Let this small step into automation increase your productivity and increase your bottom line.



SUP-600 W/ an AFS

RG-AFS will automatically ...

- push stock to cut length
- consider blade kerf
- clamp the material
- trigger the cut cycle
- release the clamp
- index to next cut position
- and repeat

# Scotchman Automation Systems



- Increase Production
- Decrease Set-up Time
- Reduce Operator Error
- Eliminate Scrap
- Step up to the next Level of Automation

PROGRAMMABLE  
STOP & AUTOMATIC  
FEED SYSTEMS



## STANDARD FEATURES

- Intuitive interface
- + or - .008 as a positioner
- Touch screen control
- 5-year warranty on drive belt
- Carriage rides on linear bearing system
- Planetary gear head, near zero backlash
- Fraction hot keys
- Switch between stop mode and pusher mode
- Downloading of cut lists via built-in wireless networking or through USB drive
- Capable of displaying picture of part print
- One-year warranty on parts
- Made in the U.S.A.

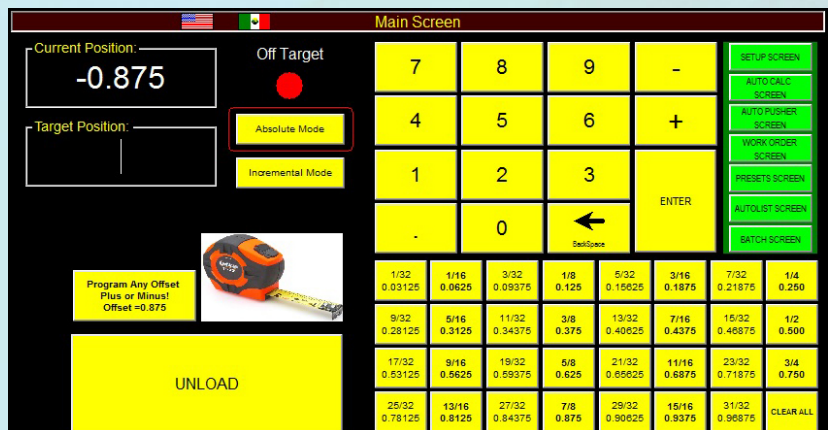

Touch Screen Control Panel

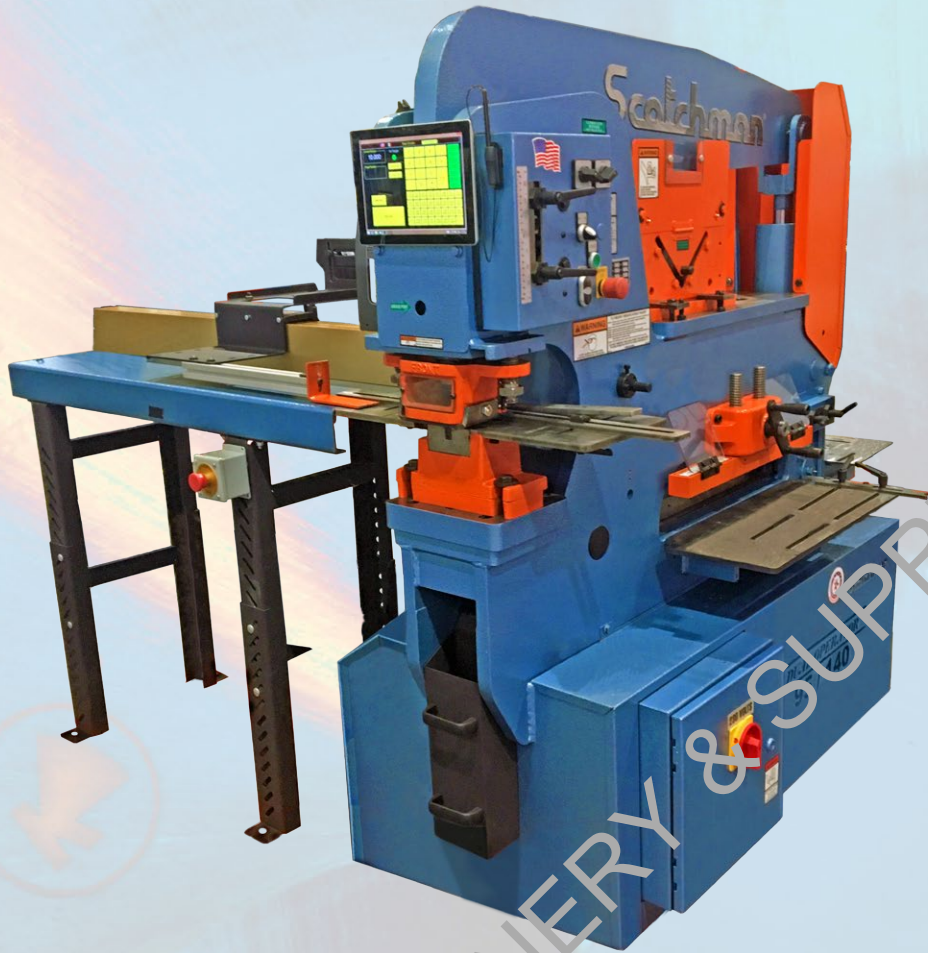

*The RG Stop System connected to the punch station of the Scotchman DO 95/140-24M Ironworker*



*The RG Stop System connected to the punch station of the Scotchman 50514-EC Ironworker*

PROGRAMMABLE  
STOP & AUTOMATIC  
FEED SYSTEMS

# Tube & Pipe Grinder/Notchers



Create perfect notches in just seconds using Scotchman's line of tube and pipe notching equipment. Available in both hand lever or crank wheel models, these notchers are ideal for steel and stainless steel (consult factory) tube and pipe construction, hand railings, gates and fences, race car frames and roll cages, marine arches railing, furniture frames and stainless plumbing for restaurant and dairy. Scotchman's notching equipment requires no costly dies, hole saws, grinding wheels or torch flame cutting.

## Manual Tube & Pipe Notchers



### MODEL & CAPACITIES

- AL1** 3/4", 1" and 1-1/4" pipe
- AL2** 1-1/2" and 2" pipe
- AL3** 1-1/4" and 1-1/2" pipe
- ALU** Vent notch; maximum .155" wall thickness

### FEATURES

- Offer efficient and productive pipe notching at low cost
- Workpiece is quickly and accurately notched to a proper fit, eliminating costly filing and grinding operations
- Portable and easy to mount to any stationary surface
- Notch several diameters up to schedule 40 wall thickness
- Require no change-over or costly attachments
- Simply insert a pipe into the die block, utilizing an eccentric shaft and lever system, and pull the handle downward ...a perfect notch every time!
- The vent notching die quickly creates a uniform notch in round or square workpieces for galvanizing outflow
- 3-Year Warranty on parts
- Made in the Netherlands

## Electric Tube & Pipe Notchers



### SPECIFICATIONS

- Motor** 3-1/2 hp \* 230v/460v \* 3ph
- Dimensions** 30" x 13-1/2" x 11-1/2"  
(762mm x 343mm x 292mm)
- Shipping Weight** AL1-2E 230 lbs. (104 kg)  
AL1-2U 230 lbs. (104 kg)

### FEATURES

- Equipped to notch 3/4", 1", 1-1/4", 1-1/2" and 2" up to schedule 40 wall thickness
- Units are available in 3-1/2 hp, 230 or 460 volt, 3ph
- For galvanizing, Model AL1-2U is equipped with a vent notching die to quickly create a uniform vent-notch in round or square workpieces for galvanizing outflow
- 3-Year Warranty on parts
- Made in the Netherlands

**CAUTION:** Never operate machines without safety guards in place. Machines are depicted with safety guards

*Safety guards are standard with AL 1-2E and AL 1-2U models to surround and protect notching dies*

TUBE & PIPE GRINDER/ NOTCHERS



# Tube & Pipe Grinder/Notchers



**AL100U-01**

MFG  
in NL



**AL100U-02**

MFG  
in NL



**AL150**

MFG  
in NL

## AL100U-01 & AL100U-02

- Produces gap-free fits ready for welding
- Smooth operation with minimal vibration
- Notches via adjustments straight = 90° to 30° in tube or pipe from 3/4" to 3" diameter in seconds (reference chart on page 39 for maximum angle with maximum diameter material)
- Two axis precision crossfeed table with hand lever feed handle and manual vise adjustment left and right (AL100U-01)
- Two axis precision crossfeed table with both handwheels and hand lever feed handle. (AL100U-02)
- Heavy duty frame and base construction
- Mandrel centerline adjustment
- One vise holds all pipe and tube sizes
- Top-mounted deburring surface
- Easy setup with vise graduated in degrees
- 13 mandrels available to ensure correct gap-free fits
- 2 belts and two pipe mandrels (1-1/4" & 1-1/2")
- Tool-free belt and mandrel change over
- 3-Year Warranty on parts
- Made in the Netherlands

## AL150

- Produces gap-free fits ready for welding
- Smooth operation with minimal vibration
- Notches via adjustments straight = 90° to 30° in pipe or tube from 3/4" to 4" diameter in seconds (reference chart on page 39 for maximum angle with maximum diameter material)
- Two axis precision crossfeed table with both handwheels and hand lever feed handle. Heavy duty frame and base construction
- Mandrel centerline adjustment
- One vise holds all pipe and tube sizes
- Top-mounted deburring surface
- Easy setup with vise graduated in degrees
- 17 mandrels available to ensure correct gap-free fits
- 2 belts and two pipe mandrels (1-1/4" & 1-1/2")
- Tool-free belt and mandrel change over
- 3-Year Warranty on parts
- Made in the Netherlands

## DIMENSIONS & SPECIFICATIONS

### AL100U-01 & AL100U-02

Belt*	4" x 78-3/4" (100mm x 2000mm)
Speed	3420 RPM
Belt Speed	98.4 feet per second
Grinding Capacity	1/2" to 3" O.D. (12.7mm to 76mm)
Angle Range	Straight = 90° to 30°
Motor	4 HP * 230v/460v * 3ph 230v * 1ph (optional)
Dimensions	59" x 47" x 19-1/2" (1499mm x 1194mm x 495mm)
Shipping Weight	460 lbs. (208 kg) AL100U-01 460 lbs. (208 kg) AL100U-02

### AL150

Belt*	6" x 78-3/4" (150mm x 2000mm)
Speed	3420 RPM
Belt Speed	98.4 feet per second
Grinding Capacity	1/2" to 4" O.D. (12.7mm to 114mm)
Angle Range	Straight = 90° to 30°
Motor	5-1/2 HP * 230v/460v * 3ph 230v * 1ph (optional)
Dimensions	59" x 47" x 26-1/2" (1499mm x 1194mm x 673mm)
Shipping Weight	600 lbs. (272 kg)

TUBE & PIPE  
GRINDER/  
NOTCHERS

# Tube & Pipe Grinder/Notcher Rollers



## TUBE & PIPE NOTCHER ROLLER SPECIFICATIONS

Pipe	Tube	Decimal size	AL100U-01 / AL100U-02—4" Part #	AL150 - 6" —Part #
1/2"		840	A042.21.3	A043.21.3
	1.000	1.000	A042.26	A043.26
3/4"		1.060	A042.26.9	A043.26.9
	1.250	1.250	A042.32	A043.32
1"		1.330	A042.33.7	A043.33.7
	1.500	1.500	A042.38	A043.38
1-1/4"		1.660	A042.42.4	A043.42.4
	1.750	1.750	A042.44	A043.44
1-1/2"		1.900	A042.48.3	A043.48.3
	2.000	2.000	A042.50	A043.50
2"		2.375	A042.60.3	A043.60.3
	2.500	2.500	A042.63.5	A043.63.5
2-1/2"		2.875	A042.73.1	A043.73.1
	3.000	3.000	A042.76.1	A043.76.1
3"		3.500		A043.88.9
	3.500	3.500		A043.88.9
3-1/2"		4.000		A043.101.6
4"		4.500		A043.114.3

TUBE & PIPE GRINDER/NOTCHERS

# Tube & Pipe Grinder/Notcher Belts

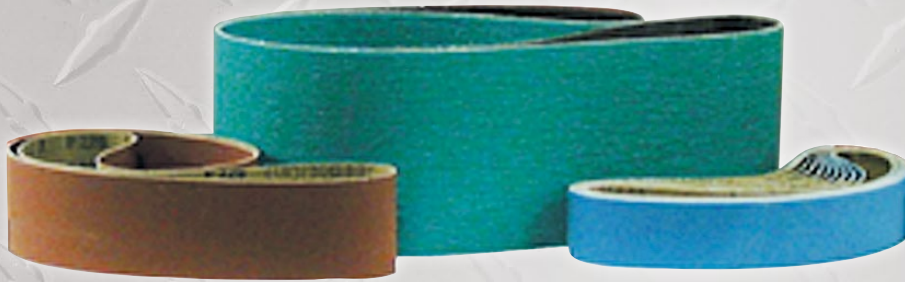

## Abrasive Notcher Belts

### PRODUCTIVITY

In most applications, abrasive belt notchers dramatically increase productivity. Unlike conventional grinding wheels, abrasive belts are self-sharpening, continuously exposing fresh cutting points. This means no more dressing or replacing expensive grinding wheels. To accurately measure productivity, divide [belt cost plus labor plus overhead] by [number of parts ground].

### METAL REMOVAL

The rate of metal removal is determined by material to be ground, belt type, belt speed (SFPM) and the amount of pressure applied during grinding. Grinding belt options are provided in the charts below.

### GRINDING BELT DIMENSIONS & SPECIFICATIONS

Length/Grit	Product No.	Packaging	Notch Diameter
4" x 78-3/4" 100mm x 2000mm / 36 GRIT	A044.00001	10 Belts Per Box	35 - 76.1 mm
	Rigid Belt for 3/4" & Larger Diameter		
4" x 77-1/2" 100mm x 1968.5mm / 36 GRIT	A044.00003	10 Belts Per Box	35 - 76.1 mm
	Flexible Belt for 3/4" & Smaller Diameter		
6" x 78-3/4" 150mm x 2000mm / 36 GRIT	A044.00002	10 Belts Per Box	35 - 114.3 mm
	Rigid Belt for 3/4" & Larger Diameter		
6" x 77-1/2" 150mm x 1968.5mm / 36 GRIT	A044.00004	10 Belts Per Box	35 - 114.3 mm
	Flexible Belt for 3/4" & Smaller Diameter		

\*Notchers with serial numbers 0001000, 0001300, 9701301-9701650 & 9801651-9801700 require 4" x 77" belts

### TECHNICAL DATA—4"

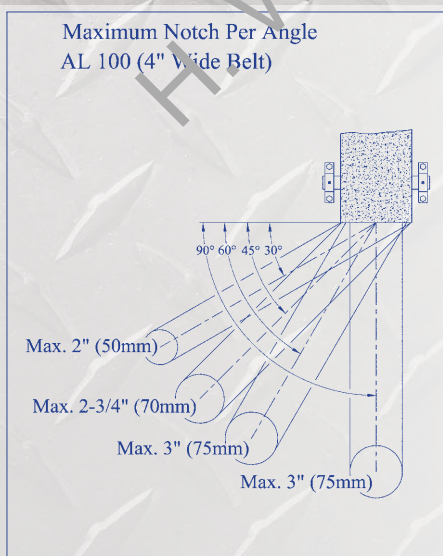

### TECHNICAL DATA—6"

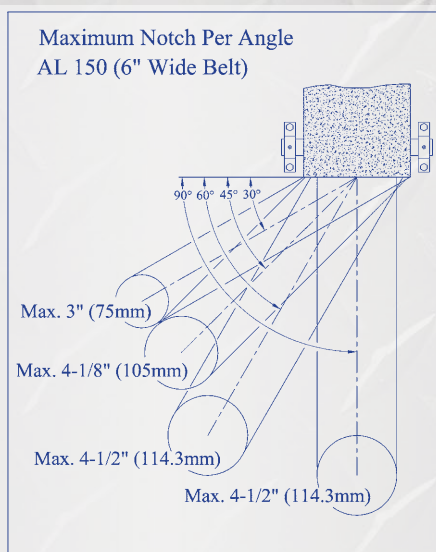

# Advanced Measuring Systems



## MULTI-LOC STOP SYSTEM

The Multi-Loc Stop System allows you to set stops at various lengths to enable you to maximize your raw stock without changing your set-up each time. These Multi-Loc versions of the AMS Gauging Systems allow you to place multiple stops on the rail as close as 1" apart on the Standard System, and 1-1/2" apart on the Heavy Duty System. Three stops come with each assembly and either system is available in Left-Hand & Right-Hand models. Additional Multi-Loc Stops are available.

To operate, simply set the stops to your cut list dimensions. Slide the material past the stops you do not want to use, right to the desired setting. Press the material against the fence and the flippers on the stops not used move away.

Multi-Loc Stop Systems are available in 1/16" increments and in standard lengths of 5', 10', 15', 20', & 25'. Longer lengths can be achieved by joining rails together.

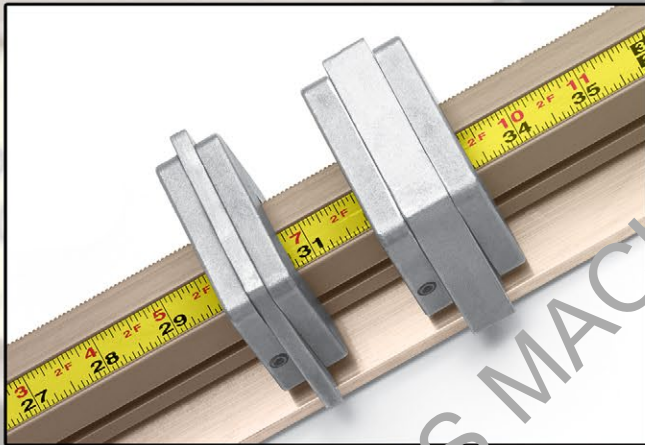

*The Multi-Loc Stop System makes setting your production runs faster. It is as easy as picking up the stainless steel stop and pressing it down at the dimension you want.*

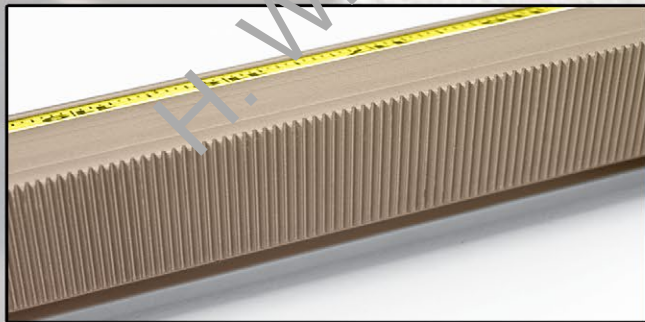

**A GUARANTEE, WITH TEETH!** While the teeth align the stop to the dimension you choose, they also add incredible strength. Once set, the teeth guarantee the stop will never slip or move. The teeth in our stop systems allow operators to increase accuracy, reduce set-up time, and eliminate waste.

## QUICK-LOC STOP SYSTEM

The Quick-Loc version is available in Left-Hand & Right-Hand models. Numerous accessories have been designed to customize this system to your special needs. A listing of the accessories can be found on the following page. It is available in increments of 1/16", and in standard lengths of 5', 10', 15', 20', & 25'. Longer lengths can be achieved by joining rails together.

Our exclusive teeth feature allows you to quickly set our Quick-Loc Stop using the built-in measure. In seconds, your work station is set up and locked in.

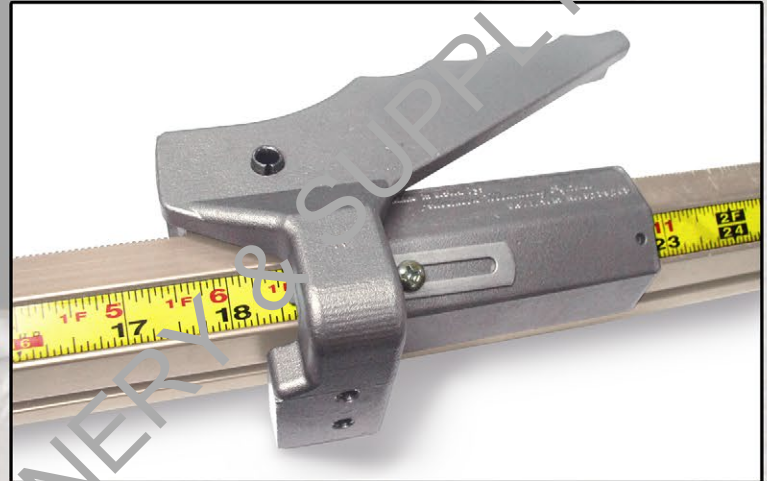

*Simply squeeze the handle on the Quick-Loc Stop System, slide it into position, and release it. The teeth on the stainless steel stop align themselves to the teeth on the rail to give you exactly the dimension you set. Once set into place, the stop cannot slip!*

### •Fast

*Simply move the stop to the correct setting and let go. The gauge aligns itself to the dimension you selected. It's as easy as picking up & pressing down the Multi-Loc or sliding the Quick-Loc to the setting.*

### •Accurate

*Once set, the teeth guarantee the stop will never slip or move, eliminating measuring errors and waste.*

### •Repeatable

*The same dimensions can be repeated again and again by different operators on different operations, even on different days.*

### •Cost Effective

*The investment will be quickly returned in lower labor costs, reduced makeovers and less waste.*



# AMS - Loc Stop System Accessories

Stop Systems for all your Gauging Applications

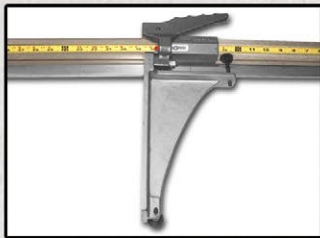

### Quick-Loc Arm

Enables you to cut several pieces together, at one time.

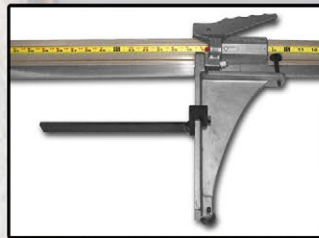

### 10" Extension shown on a Quick-Loc Arm



### 10" Flip up Extension for Quick-Loc



### 10" Flip up Extension (Raised) for Quick-Loc



### Roller Conveyor

With right-hand Quick-Loc.



### Standard Multi-Loc Stop

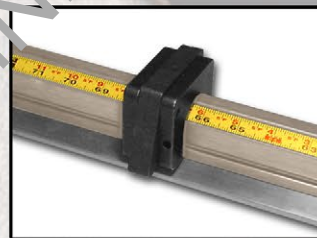

### Heavy Duty Multi-Loc

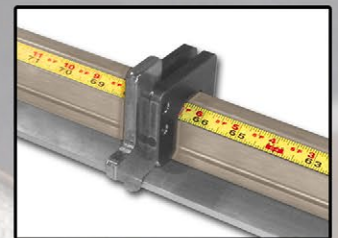

### Vertical Multi-Stop Block

Material thickness from 1/8 gauge to 3/4".

Our Patented Loc-Stop System is a state-of-the-art measuring system. Replacing your existing old style measuring devices with our exclusive Loc-Stop system will start you on the road to greater efficiency, higher productivity, and lower business cost.

The following is a partial list of possible applications:

- CUT-OFF SAWS
- RADIAL ARM SAWS
- COLD SAWS
- PUNCHING
- SHEARING
- DRILLING
- IRONWORKERS
- PRESSES

To view machinery applications ... Visit: [www.scotchman.com](http://www.scotchman.com)... and click on Scotchman Advanced Measuring Systems

# SU-280-G



## MAXIMUM CAPACITIES

Tubing	90 Degree	45 Degree	30 Degree
Round	8" 203 mm	7" 180 mm	4-1/4" 110 mm
Square	8" 203 mm	6-1/4" 160 mm	4" 110 x 100 mm
Rectangle	11" x 7-3/4" 280 x 200 mm	7" x 6-1/4" 180 x 160 mm	4-1/4" x 4"



## STANDARD EQUIPMENT & FEATURES

- Quick Action Locking Vise
- Miter Capability 30° Right
- Blade Trigger Switch
- Gravity Feed
- Adjustable Feed Rate
- Blade Tension Gauge
- Two Cutting Speeds (3-phase model)
- One Cutting Speed (1-phase model)
- Carbide Blade Guides with Roller Supports
- Recirculating Coolant System
- Band Door Interlocks
- One 1" (27 mm) Saw Blade
- One Gallon Concentrated Coolant
- Three-year Warranty on Parts
- Made in Spain

## ALSO AVAILABLE

### SU-280-M (MANUAL FEED)

Same Standard Equipment & Features as SU 280-G with the exception of those listed below;

- Manual Vise
- Manual Feed

## SPECIFICATIONS

<b>Blade Length:</b>	1" x 96.5"
<b>Two Cutting Speeds:</b>	3 phase machines, 131/262 FPM
<b>One Cutting Speed:</b>	1 phase machines, 196 FPM
<b>Motor Rate:</b>	1-1/2 hp
<b>Factory Wired:</b>	Specify 230 1-ph, 230 3-ph, or 460 3-ph
<b>Width:</b> 33-1/2"	<b>Depth:</b> 55"
	<b>Height:</b> 69"
<b>Shipping Weight:</b> 650 lbs. (295 kg)	

# Are you interested in LEASING?



## Scotchman Credit Corp is *leading* the way with **LOWER Interest Rates** on a **SCOTCHMAN LEASE/PURCHASE!**

**\*\*\*We finance other brands of equipment, too!**

**LEASING NOT AVAILABLE** IN ALABAMA, NEW JERSEY, NEVADA AND WEST VIRGINIA

### BUSINESS LEASE PROGRAM

This **Monthly** Payment Plan is available to qualified buyers through our participating dealers nationwide. One advance payment is required for each year of the lease. A \$100.00 documentation fee is required with your Advance Payment.

- **\$1.00 End of lease buyout**
- **No early payoff penalty**
- **\$4,000.00 lease minimum**
- **12 month to 60 month leases available**

### SCHOOL LEASE PROGRAM

This **Yearly** Payment Plan is available to **SCHOOLS ONLY** through our participating dealers nationwide. One advance payment is required for the yearly payment lease plan. A \$100.00 documentation fee is required with your Advance Payment.

- **\$1.00 End of lease buyout**
- **No early payoff penalty**
- **\$4,000.00 Lease minimum**
- **Available in 1 to 5 year leases**

**\*\*SIMPLE ONE-PAGE Lease Application**

available at [www.scotchman.com/leasing.php](http://www.scotchman.com/leasing.php)

# Scotchman<sup>®</sup>

## Metal Fabricating Solutions

For more information, please contact:

**Scotchman Industries, Inc.**

PO Box 850 • 180 East Hwy. 14 • Philip, SD 57567

Phone: (800) 843-8844 (605) 859-2542 • Fax: (800) 843-5545 (605) 859-2499 • Email: [sccleasing@scotchman.com](mailto:sccleasing@scotchman.com)



**In Memory of Art Kroetch**

1926-2007

*Founder of Scotchman Industries*

Established in 1967, our factory and corporate offices are family owned and located in Philip, South Dakota. Factory representatives assist dealers worldwide and we have an authorized dealer near you.

For over 50 years, Scotchman has been turning ideas into products that help metal fabricators do things easier & more efficiently. Our company goal is to produce quality products that satisfy customer needs. The results can be seen in our product line that represents solutions.



# Scotchman<sup>®</sup>

Metal Fabricating Solutions



**Scotchman Industries • 180 E. Hwy 14 • PO Box 850 • Philip, SD 57567 USA**

Call Toll Free in USA: 1-800-843-8844 • Call Direct: 605-859-2542 • Fax: 800-843-5545 or 605-859-2499

www.scotchman.com

e-mail: info@scotchman.com

Follow Us On

